

SIRUBA®

銀箭牌工業用縫紉機

INDUSTRIAL SEWING MACHINE

L381/L382/L383

使用說明書/零件圖

INSTRUCTION BOOK/PARTS LIST



CE



高林股份有限公司
KAULIN MFG. CO., LTD.

重要安全指示说明

为使您正确使用本机，须对本机的各种功能充分了解，以便安全操作。

使用前请仔细阅读使用说明书。我们希望您能长期愉快地使用本机，请保存好说明书，以备查阅。

- 1、无论您何时使用本机，须了解基本的安全事项，包括但不限于下列事项。
- 2、通读所有说明，并保存好使用说明书。如果需要，请随时翻阅。
- 3、使用本机前，必须弄清与本机有关安全规定，标准在您的国家是否适用。
- 4、使用本机前或使用本机时，所有安全装置必须配备齐全。机器运转时，无安全装置属违章操作，决不允许。
- 5、操作人员必须经过适当的培训。
- 6、为了您的人身安全，我们建议您戴上防护眼镜。
- 7、下列情况下，请关闭电源开关或拔下电源插头。
 - 7.1 机针穿线
 - 7.2 更换机针、压脚、针板、送料牙等
 - 7.3 进行维修时。
 - 7.4 操作区域无人时。
- 8、在机器加油润滑时，若不小心让油碰到眼睛、皮肤或咽下机油或润滑油，请立即冲洗被沾染部位或去医院检查。
- 9、无论机器运转与否，严禁乱动机器零部件和配套装置。
- 10、机器的维修、改造和调整等工作必须由专业技术人员进行。
- 11、应由专业受训人员进行一般的维修和检验工作。
- 12、必须在专业电器人员或专业技术人员的指导下进行有关电器部件的维修，任何电器部件一经发现受损，立即停止机器运转。
- 13、使用期间要定期全面彻底清洗机器。

- 14、正常操作本机时，必须进行试运转，工作环境远离强噪音源，如高频电焊机等。
- 15、由电器人员选择合适的插头和有地线的插座。

- 16、若需要改造或改进本机，请采用有效可行的安全措施。本公司对由此而产生的伤害不承担责任。
- 17、本机只适用于专业缝纫。

- 18、两种警告提示符



操作人员或维修人员请注意



特别注意事项

IMPORTANT SAFETY INSTRUCTIONS

To get the most out of the many functions of this machine and operate it in safety, it is necessary to use this machine correctly.

Please read this Instruction Manual carefully before use. We hope you will enjoy the use of your machine for a long time.

Please remember to keep this manual in a safe place.

1. Observe the basic safety measures, including, but not limited to the following ones, whenever you use the machine.
2. Read all the instructions, including, but not limited to this Instruction Manual before you use the machine, In addition, keep this instruction Manual so that you may read it at anytime when necessary.
3. Use the machine after it has been ascertained that it conforms with safety rules/standards valid in your country.
4. All safety devices must be in position when the machine is redady for work or in operation. The operation without the specified safety devices is not allowed.
5. This machine shall be operated by appropriately-trained operators.
6. For your personal protection, we recommend that you wear safety glasses.
7. For the following, turn off the power switch of disconnect the power plug of the machine from the receptacie.
 - 7.1 For threading needle (s) and replacing bobbin.
 - 7.2 For replacing part (s) of needle, presser foot, throat plate,feed dog, cloth gude etc.
 - 7.3 For repair work.
 - 7.4 When leaving the working place of when the working place is unattended.
8. If you should allow oil, grease, etc. used with the machine and devices to come in contact with your eyes or skin or swallow any of such liquid by mistake, immediately wash the contacted areas and consult a medical doctor.
9. Tampering with the live parts and devices. regardless of whether the machine is powered, is prohibited.
10. Repair, remodeling and adjustment works must only be done by appropriately trained technicians or specially skilled personnel.
11. General maintenance and inspection works have to be done by appropriately trained personel.
12. Repair and maintenance works of electrical components shall be conducted by qualified electric technicians or under the audit and guidance of specially skilled personnel.
Whenever you find a failure of any of electrical components, immediately stop the machine.
13. Periodically clean the machine throughout the period of use.

14. Grounding the machine is always necessary fot the normal operation of the machine. The machine has to be operated in an environment that is free from strong noise sources such as high-frequency welder.
15. An appropriate power plug has to be attached to the machine by electric technicians, Power plug has to be connected to a grounded receptacle.

16. The machine is only allowed to be used for the purpose intended. Other used are not allowed.
17. Remodel or modify the machine in accordance with the safety rules/standards while taking all the effective safety measures. We assumes no responsibility for damage caused by remodeling or modification of the machine.

18. Warning hints are marked with the two shown symbols.





Danger of injury to operator or service staff



Items requiring special attention

安全操作事项

	<p>1、为避免触电，请不要打开电机的电箱盖，也不要触摸电箱内部组件。</p>
	<p>1、为避免人身伤害，移动皮带罩，护手挡或安全装置时，请不要开动机器。</p> <p>2、为尽可能避免机器运转造成的人身伤害，手指、头部和衣服应远离上轮、皮带和电机。除此之外，上轮、皮带和电机周围不要放置任何物品。</p> <p>3、为避免人身伤害，当您打开电源开关或操作机器时，切勿将手放在机针下方。</p> <p>4、为避免人身伤害，机器运转时，切勿将手放入挑线罩内。</p> <p>5、弯针高速运转时，勿将手指放在弯针附近。另外，换弯针时，请关掉机器电源开关。</p> <p>6、为尽可能避免人身伤害，当翘起或抬升机头时，勿将手指放入机器内部。</p> <p>7、为尽可能避免机器的突然启动所造成的事故，抬起机头或移动皮带罩和皮带时，请关掉机器的电源。</p> <p>8、如果你的机器配用伺服电机，机器未运转时，电机无噪音。为避免机器的突然启动所造成的事故，请关掉机器的电源开关。</p> <p>9、为避免触电，移动电源地线时，请勿让机器运转。</p> <p>10、为尽可能避免触电或电器组件受损，在插上或拔下插头之前，请关掉电源开关。</p>

FOR SAFE OPERATION



1. To avoid electrical shock hazards, neither open the cover of the electrical box for the motor nor touch the components mounted inside the electrical box.



1. To avoid personal injury, never operate the machine with any of the belt cover, finger guard or safety devices removed.
2. To prevent possible personal injuries caused by being caught in the machine. keep your fingers, head and clothes away from the handwheel, V belt and the motor while the machine is operation. In addition, place nothing around them.
3. To avoid personal injury, never put your hand under the needle when you turn "ON" the power switch or operate the machine.
4. To avoid personal injury, never put your fingers into the thread take-up cover while the machine is in operation.
5. The looper rotates at a high speed while the machine is in operation, To prevent possible injury to hands, be sure to keep your hands away from the vicinity of the looper during operation. In addition, be sure to turn OFF the power to the machine when replacing the looper.
6. To avoid possible personal injuries, be careful not to allow your fingers in the machine when tilting/raising the machine head.
7. To avoid possible accidents because of abrupt start of the machine, turn OFF the power to the machine when tilting the machine head or removing the belt cover and the V belt.
8. If your machine is equipped with a servo-motor, the motor does not produce noise while the machine is at rest. To avoid possible accidents due to abrupt start of the machine, be sure to turn OFF the power to the machine.
9. To avoid electrical shock hazards, never operate the sewing machine with the ground wire for the power supply removed.
10. To prevent possible accidents because of electric shock or damaged electrical component(s), turn OFF the power switch in prior to the connection/disconnection of the power plug.

目 录

操作前注意事项	1
一、开车前注意事项	1
二、使用注意事项	1
三、机器规格	2
四、机器的安装	2
五、加油	2
六、面部油量调节	3
七、面线的穿法	3
八、底线的穿法	4
九、夹线器	5
十、压脚	5
十一、针距的调节	6
十二、机针的安装	6
十三、压脚高度的调节	7
十四、送料牙的调节	7
十五、送料牙与针的同步	7
十六、针杆高度的调节	8
十七、机针和弯针的调节	8
十八、弯针相对机针的同步	9
十九、弯针的勾取量	9
二十、弯针和机针间的间隙	9
二十一、保针架的同步	10
二十二、保针架的位置	10
二十三、底线打线凸轮	10
二十四、挑线杆线量调节板的位置	11
二十五、中间导线钩	11
二十六、针板的调换	11
二十七、缝纫机的保养	12
二十八、故障和措施	12
零件手册	17

Contents

Before operation	1
1.Pre-start checks	1
2.Operating instructions.....	1
3.Specification	2
4. Installation of the machine	2
5. Oiling	2
6. How to regulate oil amount by means of manipulating elements on the face plate	3
7. The threading of needle thread	3
8. The threading of bobbin thread	4
9. Thread tension asm	5
10. Presser foot	5
11. To adjust stitch length	6
12. Setting-up of the needle.....	6
13. Adjustment of the height of the presser bar.....	7
14. Adjustment of the height of the feed dog.....	7
15. The timing of feed dog and needle.....	7
16. Adjustment of the height of needle bar	8
17. Adjustment of the needle and looper	8
18. The timing of looper in reference to needle	9
19. Thread-guiding amount of the looper.....	9
20. The clearance of looper and needle.....	9
21. The timing of needle guard	10
22. Position of needle guard	10
23. Loper thread take-up cam	10
24. The position of thread-amount adjusting plate of the thread take-up lever	11
25. Frame thread eyelet	11
26. Replacement of throat plate	11
27. Maintenance of the machine	12
28. Common breakdowns and measures of trouble shooting	12
PARTS BOOK	17

操作前注意事项 / Before operation

注意:

为避免机器受损或发生事故, 切记如下:

- 在您初次使用本机前, 请彻底清洗, 除掉运输过程中的全部灰尘, 并充分加油润滑。
- 确认电压是否正常, 插头与电源连接是否正确。
- 若您的国家的电压与本机器设计电压不一致, 请勿使用本机。
- 确认电机转动方向是否正确。
- 使用本机的第一个月, 机器应在正常或低于正常转速下运转。

CAUTION:

To avoid malfunction and damage of the machine, confirm the following:

- Before you put the machine into operation for the first time after the set-up, clean it thoroughly. Remove all dust gathering during transportation and oil it well.
- Confirm that the voltage has been correctly set. Confirm that the power plug has been properly connected to the power supply.
- Never use the machine in the state where the voltage type is irrelative from the designated one.
- Confirm that the direction of rotation of the motor pulley is correct.
- Operate your machine at the normal sewing speed or less for the first month after the set-up.

一、开车前的注意事项 / Pre-start Checks

- 1、油盘内未加油绝不能开车。
- 2、机器运转时, 从上轮外侧看转向应为逆时针方向, 注意, 不能倒转。
- 3、在最初使用的第一个月中, 应把缝速降低为每分钟4000针进行缝纫作业。
- 4、按照电动机标牌上的标注, 检查电源, 电压及单相、三相是否正确。
 1. The machine shall not be started running until the completion of oiling.
 2. The rotating direction of the balance wheel, when the machine is started running, shall be in counter-clockwise one. (View from the right side of the balance wheel.) A warning shall be given in advance against making the machine run while balance wheel turning clockwise.
 3. The machine shall be under operation at less than 4,000 S.P.M. for the first month.
 4. Check power source, voltage, and phase number to see whether they are in accordance with the ratings on the name plate of the motor to be used.

二、使用注意事项 / Operating instructions

- 1、机器运转时, 请勿将手放到针的下部。
- 2、机器运转时, 请勿将手指伸入挑线杆护罩内。
- 3、机器确定停止后, 才能盘动上轮。
- 4、关掉电动机开关后, 由于惯性上的缘故, 电动机还会继续旋转一段时间, 所以要注意, 未停止转动不能将机器倾到。
- 5、机器运转时, 请勿将手指、头发或其它东西靠近或接触上轮、“V”形皮带、电动机, 也不要东西放置在它们附近。
- 6、装拆皮带罩及护指器时, 请勿开动机器。
 1. Do not put your hands under the lower part of the needle when the machine is running.
 2. Do not put your fingers into the thread take-up lever cover when the machine is running.
 3. Only when the machine stops can you turn the balance wheel by hand.
 4. After the motor switch being turned off, due to inertia, the motor will continue to rotate for a while. Be careful not to have the machine tilted unless it stops.
 5. Keep away from the balance wheel, V-belt, winder and the motor.
 6. Do not start running the machine during mounting or replacing the belt cover, finger guard, etc.

三、机器规格 / Specification

线迹形式	并列双针双线链式缝	Stitch type	Two-needle double-row chain stitch
速度	最高每分钟4500转	Speed	Max.4,500 s.p.m.
针迹长度	1.4~4mm	Stitch length	1.4~4mm
针杆行程	30mm	Stroke of needle bar	30mm
双线间距范围	1/8" 5/32" 3/16" 7/32" 1/4" 5/16" 3/8" 1/2"	Gauges of double-row	1/8" 5/32" 3/16" 7/32" 1/4" 5/16" 3/8" 1/2"
挑线形式	针针挑线	Thread take-up type	Needle bar thread take up type
弯针	独立调节式样1/8"~1/2"通用	Looper	Separately adjustable type, for the range of 1/8" to 1/2"
保针架	摇动式、固定式并用	Needle guard	Oscillating type and rigid type
膝提压脚	上升量 8~10mm	Light clearance of knee lifter	8~10mm
供油	叶片泵	Oil supply	Impeller-type pump
润滑油	2号白油	Lubricating oil	#2 while oil

四、机器的安装(图1) / Installation of the machine (Fig.1)

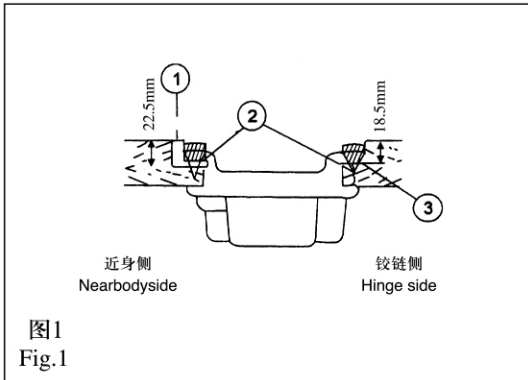

- 1、油盘的安装：将油盘支座①和油盘座③装在台板矩孔的四角，用油盘座钉②将其固定，再装上油盘。（图1）
- 2、将机头连接钩放入底板孔内，与台板的机头连接钩座相嵌合，再将机头放到四只角的缓冲垫上。

1. To install the oil reservoir.
Put the oil reservoir rubber cushion ① and oil reservoir felt cushion ③ on four corners of the opening of the table, fix them with the wood screws ②, then install the oil reservoir (Fig1)
2. Put the machine connecting hooks into the holes to engage respectively two hinges seated in the table, then place the machine on the four cushions.

五、加油(图2、图3) / Oiling (Fig.2, Fig.3)

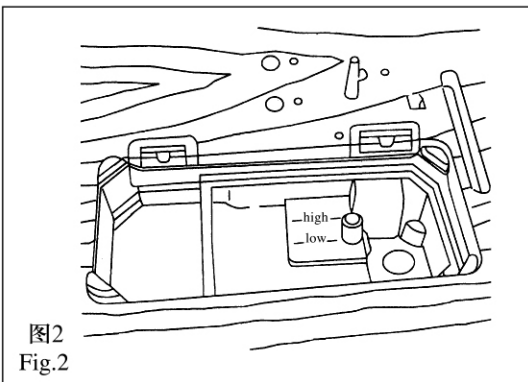

- 1、向油盘内加缝纫机油(2号白油)至HIGH记号部位(图2)。
- 2、如果油面低于LOW记号，应再加油。
- 3、加油后开动机器，润滑正常时，应看到油液喷到油窗上(图3)。至于喷到油窗上的油量多少与总油量的多少无关，所以不必担心。
- 4、如需换新油，只要拆下油盘的排油螺钉，油污就能排出。
- 5、使用新机器或长期未使用的缝纫机时，需抬起压脚以每分钟3500~4000针的速度空转约10分钟。

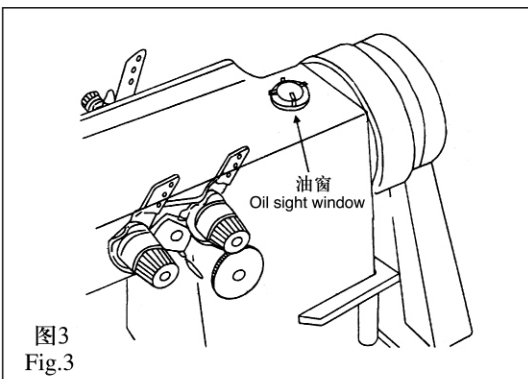

1. Oiling shall be made in oil reservoir and the oil surface also be made to level the mark "High" before the machine is started running (Fig.2)
2. Oiling shall be kept on until the oil surface has been brought above the mark "Low" (Fig.3)
3. The normal condition of lubrication is that the oil shall spray onto the oil sight. The amount of oil spraying onto the oil sight is not at all proportional to the total amount of oil in the oil reservoir. There is nothing to worry about.
4. Only when the drain cover screw is loosened and taken off can old oil be drained out and new oil is supplied again.
5. When a new model or those standing idle for long time is to be operated, presser foot shall be lifted and run idle for about ten minutes.

六、面部油量调节(图4) / How to regulate oil amount by means of manipulating elements on the face plate (Fig.4)



图4
Fig.4

转动油量调节销，可以调节针杆连杆销的供油量调节销的刻点，靠近针杆连杆销时，油量最小，反之，则油量最大(图4)
注意：调节油量时要十分注意，供油量并不是随调节立刻变化的。

To turn oil-amount adjusting pin to regulate oil amount of the thread take-up crank, min.oil amount will be supplied when the mark of adjusting pin moves to the thread take-up crank as near as you desire. Otherwise, max.oil amount will be supplied.

七、面线的穿法(图5) / The threading of needle thread. (Fig.5)

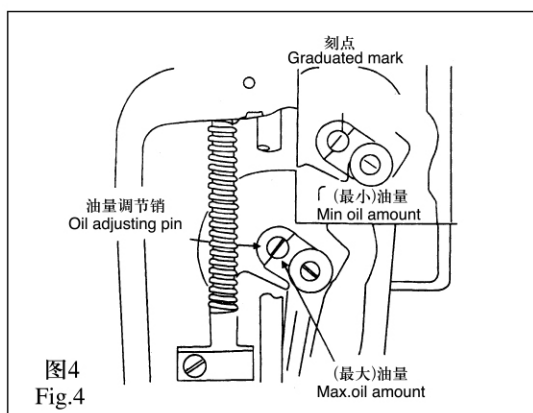
在针杆上升到最高位置时，按图5所示顺序依次穿过各线孔。

1. 线从操作者一侧向外穿过机针。
2. 面线穿过机针后必须再拉出100mm长线头。

To thread the eyes of the needles in the order as shown in Fig.5:

- 1) To make thread go through the eye of the needle outwards. (View from the operator's side)
- 2) To pull out 100mm of the remaining thread after needle thread going through the eyes of the needles.



图5
Fig.5

八、底线的穿法(图6、图7) / The threading of bobbin thread (Fig.6、 Fig.7)

底线按图示顺序依次穿过各线孔。

- 1、按(图6)所示穿过夹线器单面导线板,如用捻度大的线或缝纫时需送料距大的时候应穿二个孔。
- 2、把(图7)中的扳簧朝操作人员侧拉,A就向上抬起。
- 3、穿弯针线时,用附件中的镊子按图所示将线穿过,在弯针的前端来出50mm长线头。

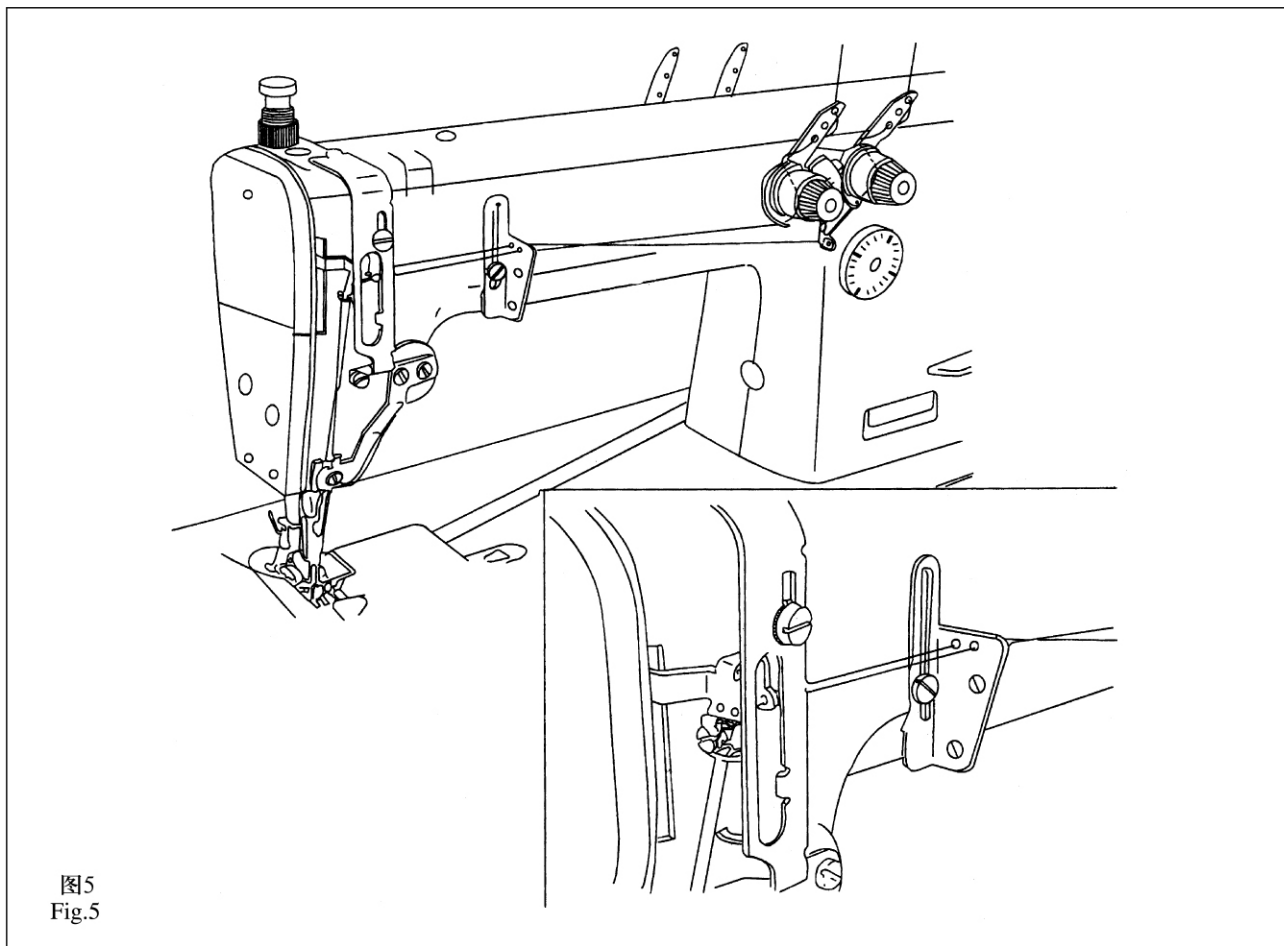
To make bobbin thread going through the eye of the needle in the order as shown in (Fig6 and Fig7)

- 1) Make the bobbin thread go through the tension guide plate; go through the two holes when thread of harder twist fibre is used and feed gauge is wider than Usual.
- 2) Pull the spring toward the operator, as shown in Fig.7 and part A will rise upwards.
- 3) When threading the looper, the thread shall be made go through the eye of the needle with a tweezer as shown in Fig.7 and 50mm of remaining thread be pulled out.

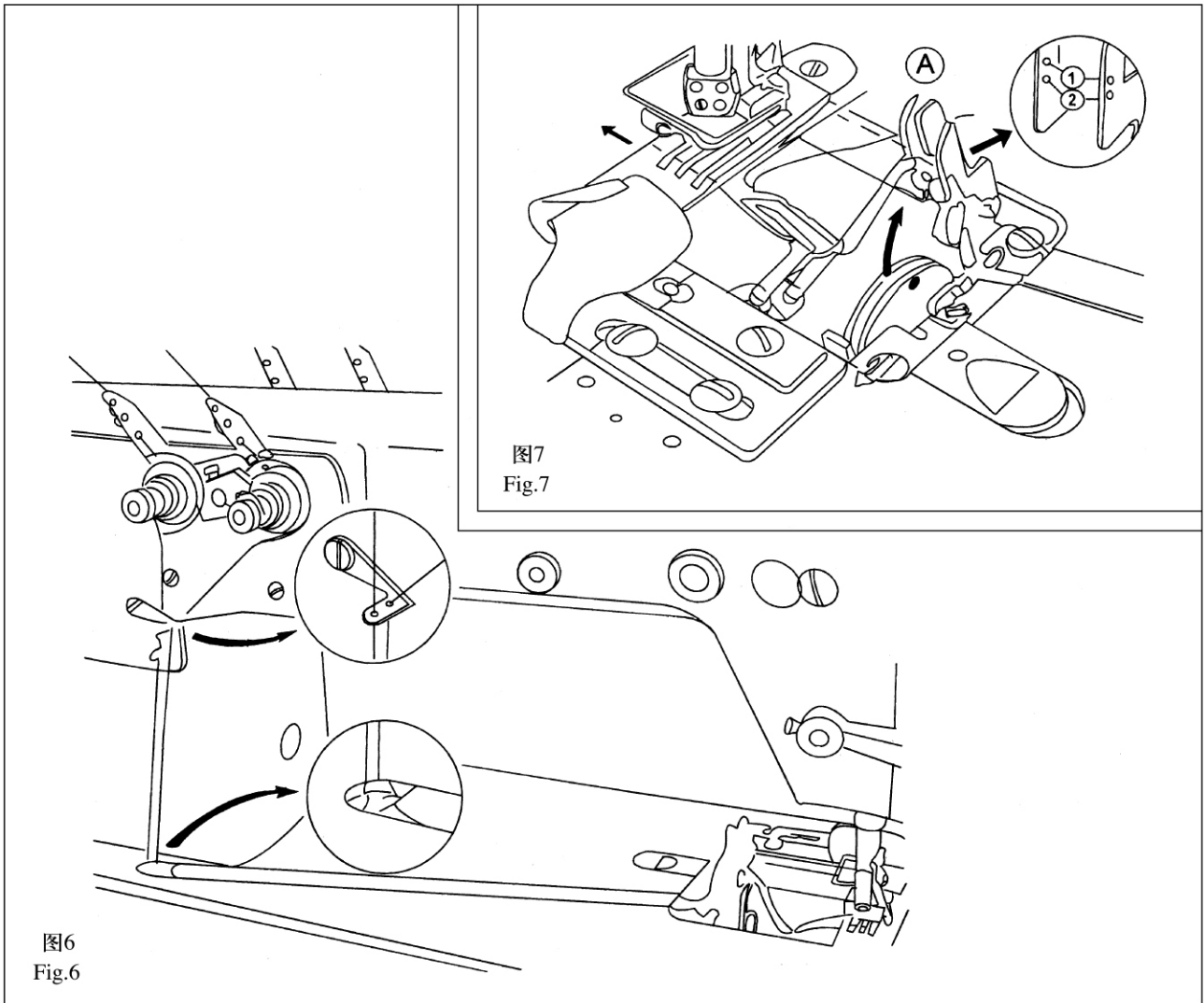

九、夹线器(图8、图9、图10) / Thread tension asm. (Fig.8、 Fig.9、 Fig.10)

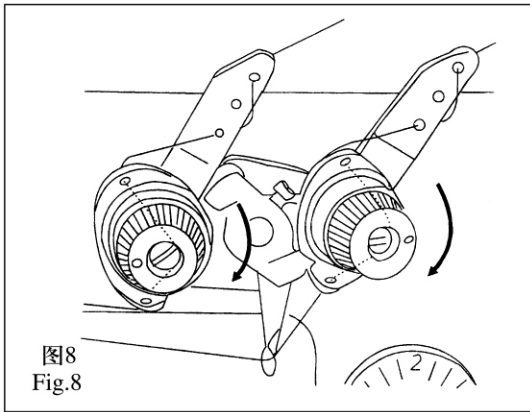

面线张力的调节(图8所示):向右转动夹线螺母张力变大。
底线张力的调节(图9所示):向右转动夹线螺母张力变大。
底面线的关系(图10所示)为链式线迹的形成。

To adjust needle thread tension is accordance what sewing working condition,we can adjust needle thread tension by tension spring.Turn the tension nut clocwise to increase to increase the tension; turn counter-clockwise to decrease the tension.

To adjust bobbin thread tension:

Turn tension screw clockwise to increase the tension;turn tension screw counterc lockwise to Tension; turn tension screw counterclockwise to decrease the tension.

The relation between the needle thread and the bobbin thread as shown in (Fig.10) depicts the forming of chain stitch.

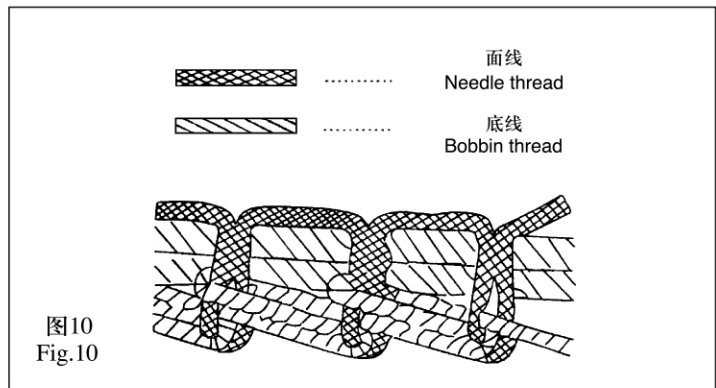
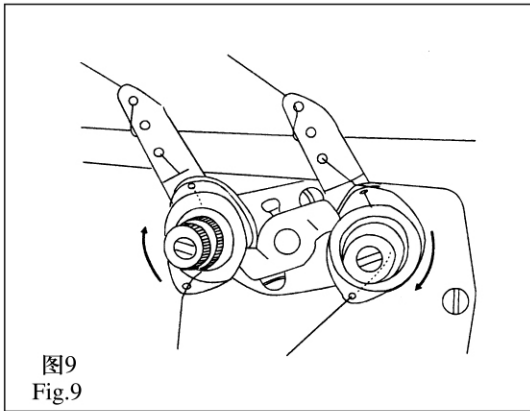

十、压脚(图11、图12) / Presser foot (Fig.11、 Fig.12)

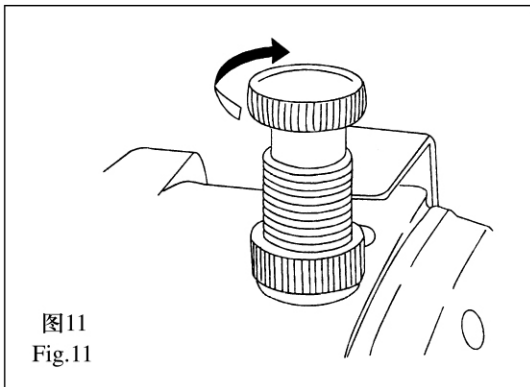

压脚压力的调节(图11):顺向转动压脚调压螺钉,压力增强,反之则压力减弱。对一般布料而言,压脚调压螺钉的标准高度为27~30mm(5公斤)左右。

要使压脚保持在抬起位置,只要把压脚扳手向左或向右转动即可(图12)。

Adjustment of pressure on presser foot (Fig.11)

Turn pressure regulating thumb screw clockwise to increase the pressure; turn pressure-regulating thumb screw counter-clockwise to decrease the pressure.For general fabric the standard height of pressure regulating thumb screw is about 27-30mm (5kg)

The presser bar lifter shall be turned either leftward or rightward in order to keep the presser foot under the condition of lifting position.

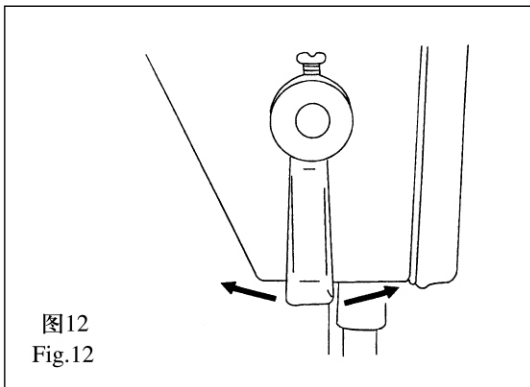

十一、针距的调节(图13) / To adjust stitch length (Fig.13)

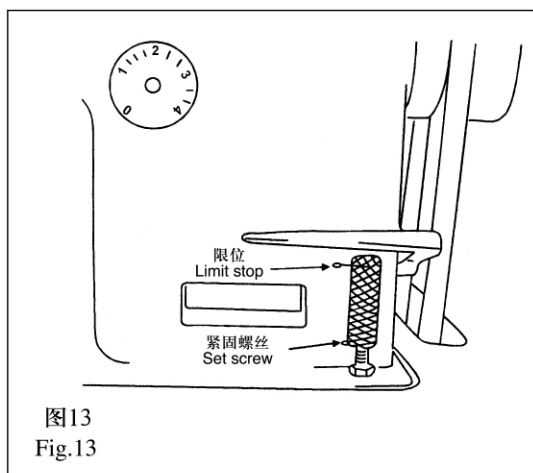

- 1、针迹长度的调节(图13)只要旋转倒送料扳手上的针距调节旋扭至所需数字即可。旋扭上刻度的数字用mm表示。
- 2、针迹从大到小改变送料刻度时，应一边将倒送料扳手朝下压；一边转动送料距旋扭。
- 3、针迹长度最大是4mm，最小是1.4mm。
- 4、按下倒送料扳手，针迹变为紧密缝(1.4mm)，该功能可用于起始和终止缝或需加强缝纫的部分。
- 5、本机不能进行倒缝。

1. Turn feed regulating adial to the figure desired. The value of graduation is shown in millmetren(mm)
2. If you intend to change the stitch length, press down the reverse feed lever while turning the feed regulating dial.
3. Max.,stitch length is 4mm:Min.stitch length is 1.4mm.
4. When reverse feed lever is pressed down, tight-needle stitch of 1.4mm will be formed;this version of stitch is suitable for beginning and end seaming or partaking.
5. The machine can not make reverse stitching.

十二、机针的安装(图14、图15) / Setting-up of the needle (Fig.14、 Fig.15)

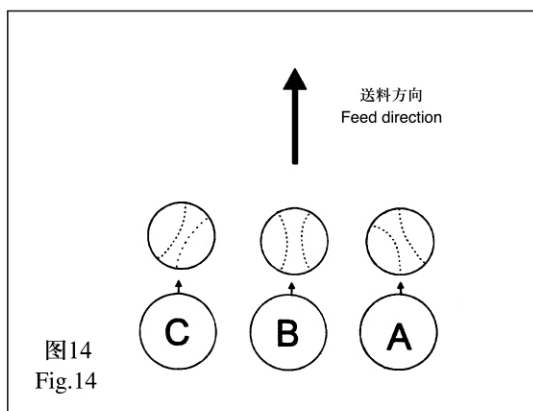

在使用化纤线时，机针针孔的方向不能如(图14)中C的方向安装。

机针请使TVx7的#9~#21型机针。用化纤线缝制时，可按(图15)所示形式放置硅油，油箱应另外定制。

When thread of chemical fibre is used,the direction of the needle eye shall not be in that one, as shown in part C of Fig.14. Needle types to be desired fall within the range of #9 to #21 of TVx7; Oil tank shall be custom-made when thread of chemical fibre is used; silicone oil can be placed like that, as indicated in Fig.15.

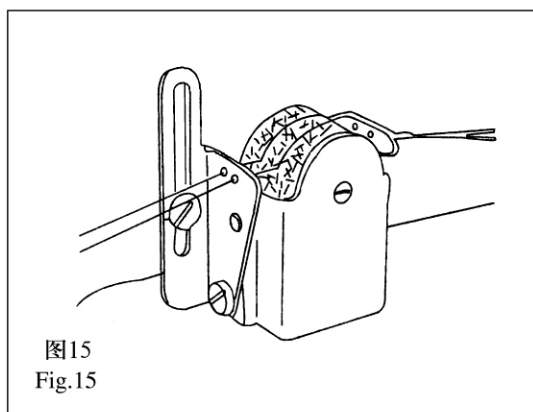

十三、压脚高度的调节(图16) / Adjustment of the height of the presser bar: (Fig.16)

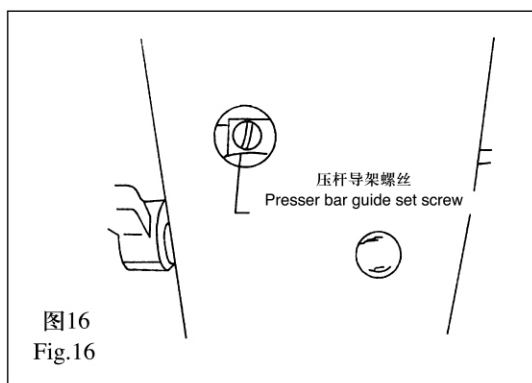

为了调换压脚或改变高度、角度需要:

- 1、拆下面板上的孔塞 (图16)
- 2、旋松压杆导架的紧固螺钉进行调节。
- 3、调节后旋紧紧固螺钉。

For the requirements of either replacing the presser foot or changing the height and angle of presser foot, the following shall be observed.

1. Take off the rubber plug in the hole from the face plate, as shown in Fig.16.
2. Loosen the presser bar guide bracket set screw.
3. After adjusting, retighten the screw.

十四、送料牙的调节(图17、图18) / Adjustment of the height of the feed dog (Fig.17、 Fig.18)

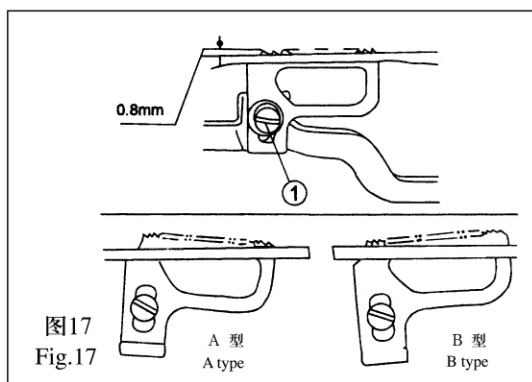

旋松(图18)所示螺钉②, 送料牙的倾角即可调节成标准型、A型、B型, 送料牙最大突出量是0.8mm,用(图17)中螺钉①调节。

Loosen the set screw ②, as shown in Fig.18, the angle of the feed dog can be adjusted to the specified one of standard version, A version, and B version. The Max. height of 0.8mm of the projection from dog is adjustable by the adjusting of screw ① as shown in Fig.17

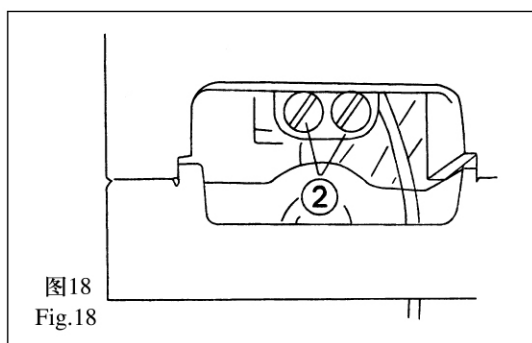

十五、送料牙与针的同步(图19) / The timing of feed dog and needle (Fig.19)

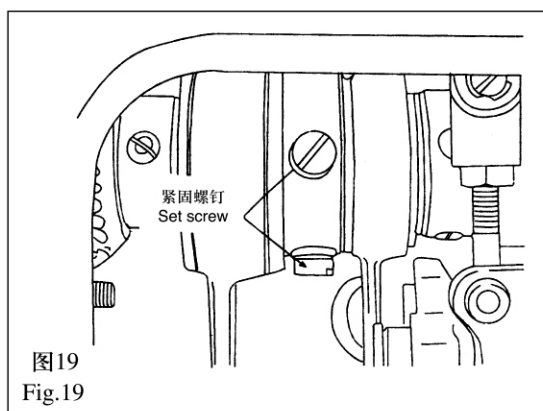

针尖下降至针板上平面3mm时, 送料牙刚好全部下降至针板上平面以下, 此时, 正好同步。可调节(图19)中的螺钉。

When the point of needle lowering down to the location of 3mm from the upper surface of the throat plate, the feed dog is right at the position below the upper surface of the throat plate, viz. The running of feed dog being well regulated in relation to the motion of needle.

十六、针杆高度的调节(图20) / Adjustment of the height of needle bar (Fig.20)

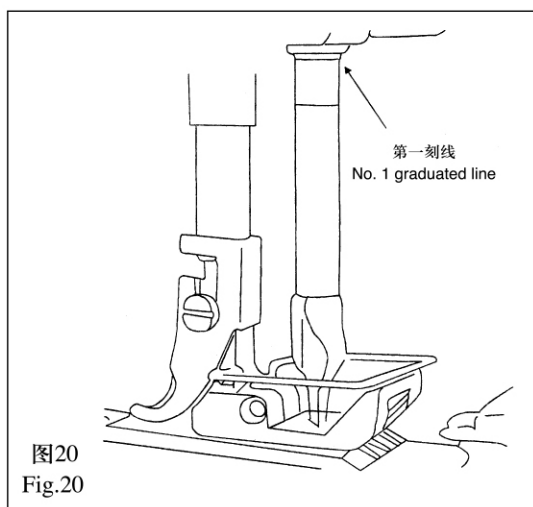

使用TVX7机针时，可用针杆上的刻线，针杆在下死点时，针杆上刻线应对准针杆下衬套的下端面(如图20所示)，这样就决定了针杆的高度。

When the needle of TVX7 is used, if the graduation on the needle bar is at the bottom dead centre, the mark of graduation shall be in line with the lower end of the needle bar bushing, lower, as indicated in Fig20.

十七、机针和弯针的调节(图21、图22) / Adjustment of the needle and looper (Fig.21, Fig.22)

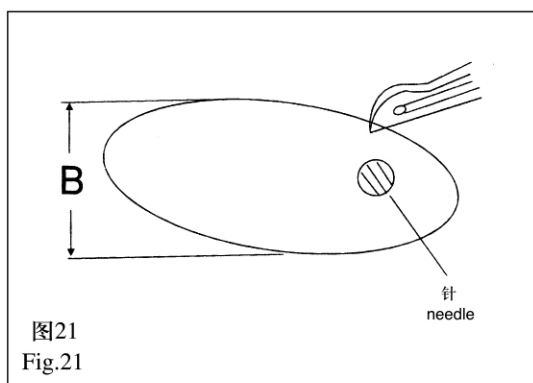

弯针前后运动量的调节：

按如下顺序调节可得弯针椭圆运动中(图21)所示的B尺寸，通常B的尺寸在最大时为3.7mm，各种规格的机针都能缝纫。

1. 拆下弯针曲柄罩壳上的橡胶塞(图22)
2. 用手转动上轮。
3. 先旋松定位螺钉和紧固螺钉，调节有标号的螺钉。
4. 把调节螺钉上的冲印标记向右旋转，则B的尺寸就会变大，反之变小。
5. 旋紧定位螺钉和紧固螺钉。

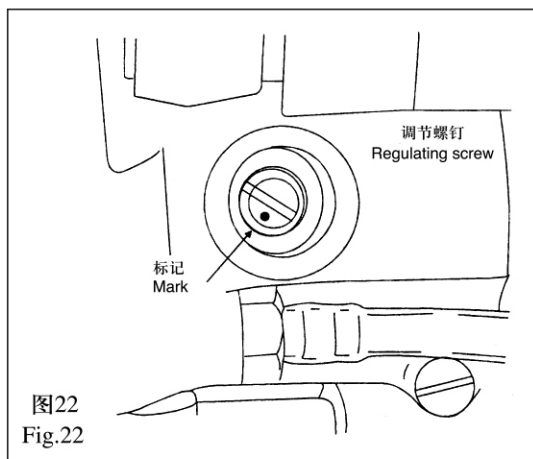

Adjustment of forward & backward motion of the looper:
The dimension of part B of the looper in an elliptic motion can be measured,(refer to Fig21).The max. dimension of part B is usually 3.7mm, suitable for sewing operation of needles of all kinds of sizes.

The adjusting procedure is as follows:

- 1) Take off the rubber plug on the crank case of the looper (refer to Fig22)
- 2) Turn the balance wheel by hand.
- 3) First loosen set screw and positioning screw, and then adjust marked screw.
- 4) Turn clockwise the adjustable screw on which punch mark is printed, and the dimension of part B will be increased in value.
- 5) Tighten set screw and positioning screw.

十八、弯针相对机针的同步(图23) / The timing of looper in reference to needle (Fig.23)

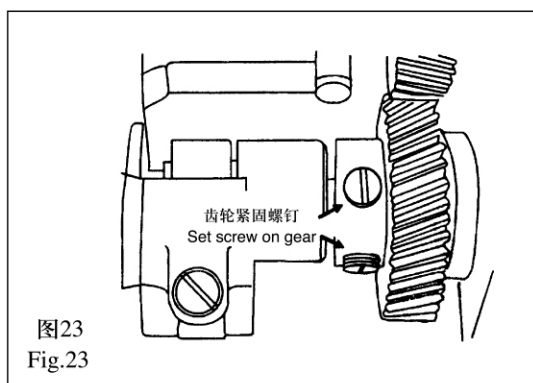

机针在最低点时，弯针退到最后，旋松图示齿轮的螺钉进行同步调整(如图23)。

The looper shall be moved backward to the lowest position while the needle is at the bottom dead centre; loosen the screw on the gear and make timing adjustment of the looper in relation to the needle (refer to Fig 23.)

十九、弯针的勾取量(图24) / Thread-guiding amount of the looper (Fig.24)

- 1、弯针的针尖到达机针的中心位置时，弯针针尖离机针孔上端的距离标准值是2mm，此时针杆下刻线和针杆下衬套下端面对齐。(如图24)
- 2、弯针的后退量约3.5mm。
- 3、机针孔和弯针孔的相对关系如(图24)所示。(左右弯针可以分别调整)

1) The standard value of the vertical distance of the point of the looper away from the upper end of the eye of the needle is 2mm, then the graduation mark on the lower part of the needle bar shall be in line with the lower end of the needle bar bushing, lower.(refer to Fig.24)

2) The value of the stroke moved backward by the looper is about 3.5mm.

3) The relation between the eye of the needle and the eye of the looper is indicated Fig.24.

(Note that the left looper and the right one can be separately adjusted.)

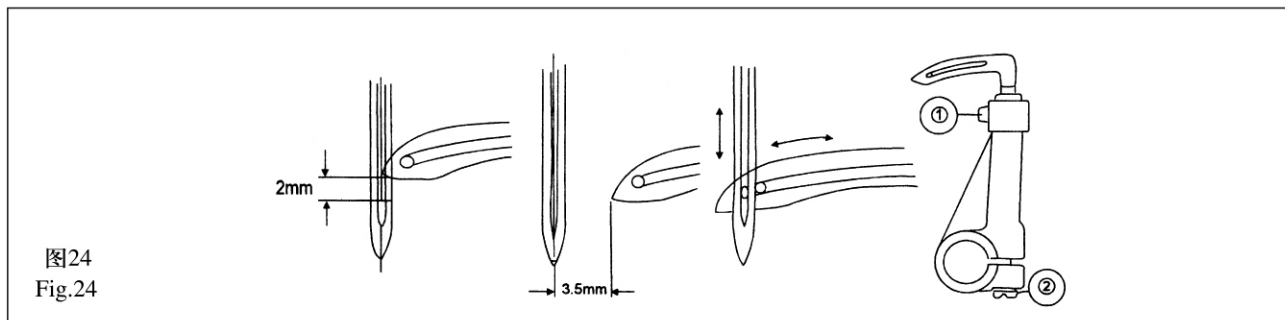

二十、弯针和机针间的间隙 / The clearance of looper and needle

保针架调整后，机针和弯针间应留有一定间隙，即用手指轻压机针，机针也不应碰到弯针针尖。如果间隙太小了，机针的侧面与弯针针尖就会因相互碰撞而损伤。

After adjusting the needle guard, the clearance of a given value between the needle and the looper shall be kept unchanged; the needle shall not touch at the point of the looper when it is pressed down softly. If the clearance is narrower than usual, the side of the needle and the point of the looper are apt to incur breakage due to the impact of the needle side against the looper point.

二十一、保针架的同步(图25) / The timing of needle guard (Fig.25)

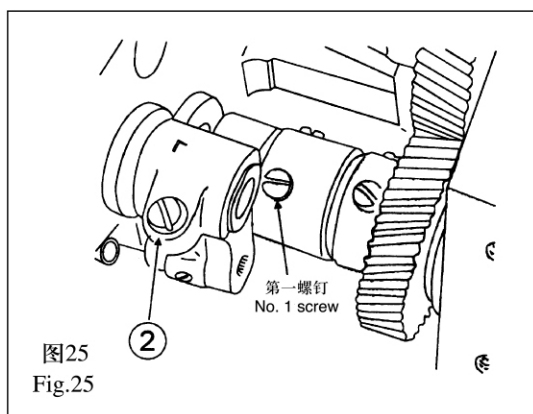

保针架的同步，由（图25）中第一螺钉旋入弯针轴上的平面而决定。

The timing of the needle guard depends on the condition of the plane on the rock shaft of the looper when no.1 screw has been screwed into this rock shaft.

二十二、保针架的位置(图26) / Position of needle guard (Fig.26)

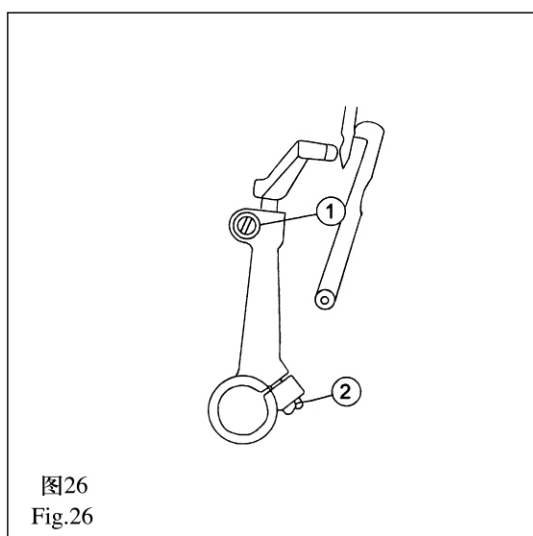

摆动保针架位置，使弯针勾取面线时让机针的针尖轻轻触及保针架，其高度应调整到不触及固定保针架范围，旋松(图26)中螺钉①②即可进行调节。

固定保针架和摆动保针架之间的关系(如图26)所示，与机针的间隙为0.1~0.2mm，缝纫机运转时不能强行夹住机针。

Oscillating the needle guard to make the needle tip contact with needle gauge slightly.

It is recommended that the height adjustment shall not fall within the area of the left counter needle guard. The adjustment can be made by loosening screw ① and ②. The relation between left counter needle guard and the counter needle guard is as represented in Fig 26; the clearance from the needle falls within the range of 0.1 to 0.2mm.

Note that the forced clamp of the needle shall be prohibited when the machine is in motion.

二十三、底线打线凸轮(图27) / Looper thread take-up cam (Fig.27)

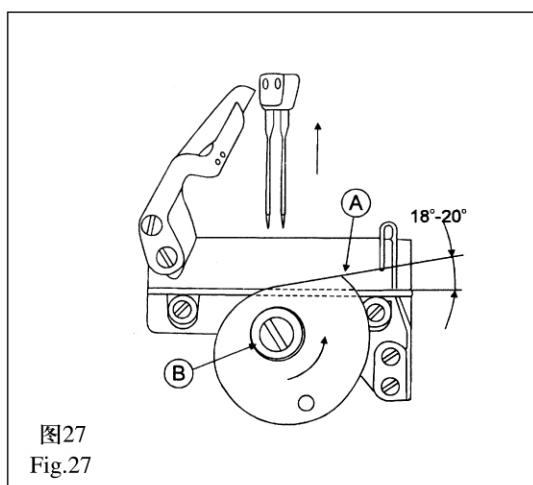

底线打线凸轮的位置如（图27）所示，针杆在最高点时，打线凸轮平面部分和钢丝平行部分的夹角为 18° — 20° ，旋松螺钉B进行调整，位置决定后再旋紧。

调整时请注意下列事项：底线从打线凸轮的突端A脱出时，针尖要完全进入底线弯针的线环中。

Its position can be seen as shown in Fig.27 when the needle bar is at the top dead centre, the planes of the cam and the steel wire are in parallelism; the projecting part of the cam can slightly rise at the angle of 18 to 20 degrees. first loosen screw B, and then make adjustment, finally tighten the screw fitmly. Pay close attntion to the following; the needle tip shall entirely come into the thread loop of the looper when the bobbin thread rejecting from the projecting part of the cam.

二十四、挑线杆线量调节板的位置(图28) / The position of the thread-amount adjusting plate of the thread take-up lever (Fig.28)



图28
Fig.28

针杆在最低点时，如(图28)所示，用挑线杆线量调节板挡住面线，这样勾取面线时，面线线环变大。

此外，针杆在最低处时，也有拉紧面线线环的作用，通常在使用较细的缝纫时，应把线量调节板降到最低点。

The thread-amount adjusting plate will retain the bobbin at thread when the needle bar is the bottom dead centre; in such a way the loop of the needle thread is to become bigger when the needle thread is hooked. In addition to the foregoing there is a function of the tight pulling of the needle thread loop. The thread-amount adjusting plate usually reduces to the lowest point when a thread finer than normal is used.

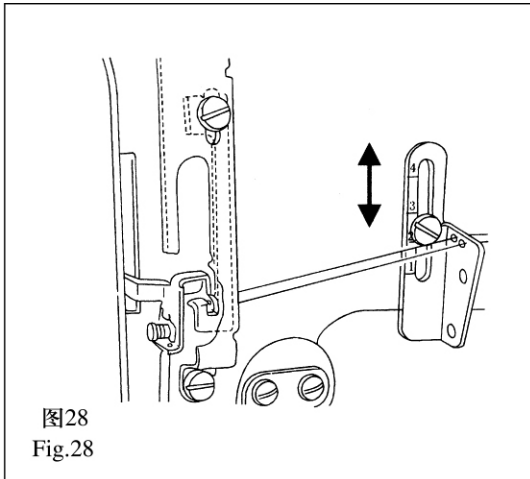
Note that take-up thread tension lever is another name for thread-amount adjusting plate.

二十五、中间导线钩(图29) / Frame thread eyelet (Fig.29)



图29
Fig.29

中间导线钩的位置也关系到跳针现象发生，一般把下列位置作为基准(图29)

棉 线#80~#50	中间导线钩刻度2-3
棉 线#30~#20	中间导线钩刻度3-4
化纤线#80~#50	中间导线钩刻度1-2
化纤线#30~#20	中间导线钩刻度2-3

The improper-positioning of the frame thread eyelet may be the cause of occurrence of skipping stitch. The following locations are generally regarded as criteria (refer to Fig.29)

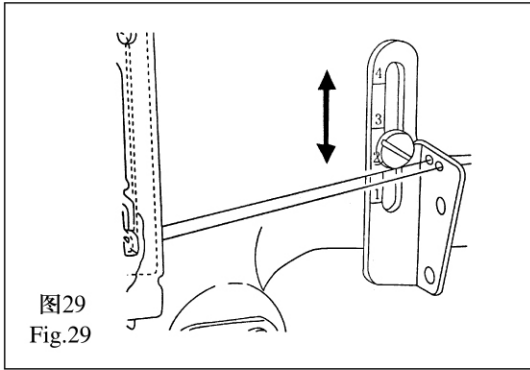
Cotton thread#80~#50	Graduation marked on the frame thread eyelet 2-3
Cotton thread#80~#50	Graduation marked on the frame thread eyelet 3-4
Thread of chemical fibre #80~#50	Graduation marked on the frame thread eyelet 1-2
Thread of chemical fibre #80~#50	Graduation marked on the frame thread eyelet 2-3

二十六、针板的调换(图30) / Replacement of throat plate (Fig.30)



图30
Fig.30

单针链缝机的针板出厂标准规格为1/4" (6.4mm)。(图30) 改变缝线间距通常同时要更换：

1、针夹 2、活压脚 3、针 4、送料牙 5、摆动护针杆 6、卷边器左弯针和右弯针在1/8"~1/2"针板规格之内都通用。针板宽度大时，除上述零件外还要调换推板和凸轮盖。

The standard size of the throat plate in parts book, which is stipulated by the manufactory, is 1/4", equivalent to 6.4mm. (Fig.30)

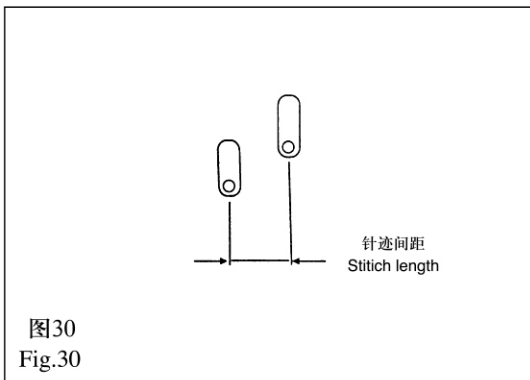
The replacement of the following components is usually needed at the time when changing the gauge of double-row thread stitch.

- 1.Needle clamp 2.Hinged foot 3.Throat plate 4.Feed dog 5.Rear moving needle guard 6.Curler

The left and right loopers within the range of the sizes of 1/8" to 1/2" are interchangeable.

In addition to the aforesaid, the replacement of slide plate and cam cover shall be made when the width of thread plate is on the increase.

二十七、缝纫机的保养 / Maintenance of the machine

为了使缝纫机保持良好的工作状态，要做到以下事项：

(一) 每日必须检查的事项：

- 1、运转时，油窗内的油在飞溅。
- 2、运转时，一听到有异常声音，即应停止缝纫作业，并请修理工来检查。

(二) 每周一次检查部位：

- 1、拆下针板、推板、凸轮盖，用刷子清洗送料牙槽中的灰尘。
- 2、把机头翻转，去除油泵过滤网上的垃圾及油盘内的灰尘。
- 3、发现润滑油黑脏时，只需旋下油盘的排油螺钉排空污油，换入新的润滑油。
- 4、油面必须高于最低线（LOW）
- 5、用布揩去沾在油盘磁铁上的黑粉。

The following shall be abhered in order to keep the machine in good working condition.

(1) Daily checking

- I. The oil shall spray onto the oil sight when the machine is running.
- II. Repairman shall be sent for when abnormal sound is heard during the operation of the machine.

(2) Locations to be checked once a week:

- I. To take off throat plate. slide plate, and cam cover; to clean dust of the slotted feed dog with a brush.
- II. To turn over the head to rid both the oil filter screen on the oil pump and the interior of the oil reservoir of oil stain and dust.
- III. Loosen drain hole screw and take it off; drain all the dirty oil from the oil reservoir and reoil it.
- IV. Oil level must be above the lowest oil-level-indicating line marked "Low"
- V. The black powder, adhering to the magnet in the oil reservoir shall be wiped with sponge cloth.

二十八、故障和措施 / Common breakdowns and measures of trouble shooting

序号	事故内容	原 因	对 策
1	断 线	1、缝线质量差 2、缝线太粗 3、机针过热熔断缝线 4、缝线张力太强 5、机针、弯针、针板、保针架过线部分损伤 6、线量未调节好	1、使用质量好的缝线 2、调换合适的缝线 3、使用硅油或降低转速 4、旋松夹线螺母 5、用油石磨光再抛光 6、调节线量调节板

2	跳 线	1、面线跳针	<ul style="list-style-type: none"> 1、调整弯针勾取量 2、调整弯针与机针的间隙 3、调整机针同弯针的同步 4、根据缝线的情况调整线量调节板 5、调整中间导线钩的位置 6、检查机针安装是否正确 7、检查保针架的位置和同步是否正确 8、检查缝线是否穿正确
		2、底线跳针	<ul style="list-style-type: none"> 1、按上述面线跳针1、2检查 2、检查底线凸轮的同步 3、稍微增强底线的张力 4、检查缝线穿得是否正确
		3、使用化纤线时的跳针	<ul style="list-style-type: none"> 1、使用硅油 2、降低转速 3、使用化纤线用的机针
		4、使用合成纤维线时的跳针	<ul style="list-style-type: none"> 1、降低转速 2、使用硅油
3	线迹不良	<ul style="list-style-type: none"> 1、面线张力太弱 2、底线张力太弱 3、缝线太粗 4、中间导线钩的位置不够正确 5、挑线杆线量调节板位置不正确 6、针板 	<ul style="list-style-type: none"> 1、旋紧面线夹线螺母 2、旋紧底线夹线螺母 3、调换大号机针 4、调整中间导线钩的位置 5、调整线量调节板的位置 6、使用针孔大的针板
4	断 针	<ul style="list-style-type: none"> 1、机针弯 2、送料和机针不同步 3、压脚的安装有问題 4、保针架有问題 5、面线张力过强 6、机针太粗 	<ul style="list-style-type: none"> 1、调换机针 2、调整到同步 3、压脚孔、针板孔的中心与机针中心要一致 4、检查保针架的位置和同步 5、放松面线张力 6、使用合适的机针
5	起 绉	<ul style="list-style-type: none"> 1、缝线张力过强 2、底线打线凸轮不同步 3、各过线处光洁度有问題 4、压脚压力太强 	<ul style="list-style-type: none"> 1、降低缝线张力，特别是底线的张力 2、进行调节，使其同步 3、研磨各过线部件 4、旋松调压螺钉

No.	Breakown	Cause	Measures to be taken
1	Therad breakage	<ol style="list-style-type: none"> 1 Poor thread quality 2 Thread being too thick 3 Fusing thread due to high temperature of needle caused by machines operation at high speed 4 Tension being too higher 5 Breakage of needle, looper, throat plate, and needle guard at the location of thread guide 6 Failure to adjust thread amount 	<ol style="list-style-type: none"> 1. Quality thread to be used. 2. Replacement to be made by an appropriate thread 3. Silicone oil to be used and speed to be reduced 4. The tension nut to be loosened 5. First grinding with oil stone and then polishing 6. Adjusting the thread amount adjusting plate
2	Skipping stitch	1. Skipping stitch of needle thread (leaking of two stitches due to the loopers failure to hook the needle thread)	<ol style="list-style-type: none"> 1. Adjusting thread-hooking amount of looper. 2. Adjusting clearance between looper and needle. 3. The timing of needle in reference to looper. 4. Adjusting the thread-amount adjusting plate on thread amount changing conditions. 5. Adjusting the frame thread eyelet. 6. Checking whether the mounting positon of the needle is proper or not. 7. To see if the location of needle guard is in an appropriate way and the timing of it is well regulated in relation to another. 8. To see if the needle thread threading is in a proper way.
		2. skipping stitch of bobbin thread (leaking of one stitch, needle failure to enter the looper eyelet)	<ol style="list-style-type: none"> 1) Reference to the above cases 1 and 2, as to skipping stitch of the needle of the needle thread. 2) To see if the timing of bobbin thread cam has been well reulated. 3) Increasing tension of bobbin thread a bit higher. 4) To see if the threading of bobbin thread is in a correct way.
		3. Skipping stitch when thread of chemical fribre being in use	<ol style="list-style-type: none"> 1) Using sillicone oil 2) Reducing speed 3) Using needle for threead of chemical fibre.
		4. Skipping stitch when thread of polyester fibre being in use	<ol style="list-style-type: none"> 1 Reducing speed 2 Silicone oil to be used
3	Twisted stitches	<ol style="list-style-type: none"> 1. Needle thread tension being too low. 2. Bobbin thread tension being too low 3. Sewing thread being too thick 4. Improper position of the frame thread eyelt. 5. Improper position of thread take-up tension plate 6. Throat plate 	<ol style="list-style-type: none"> 1. Tightening tension nut of needle thread. 2. Tightening tension nut of bobbin thread. 3. Needle of large size to be used. 4. Readjusting it to a proper position. 5. Readjusting its position in an appropriate way. 6. the eyelet of throat plate to be used being bigger than normal one.

4	Breakage of needle	<ol style="list-style-type: none"> 1) Needle being bent. 2) The operation of feed dog being not well regulated in reference to the motion of needle. 3) Setting-up of the presser foot 4) The problem of the timing of needle guard remaining unsolved 5) Needle thread tension being too high. 6) Needle being too thick. 	<ol style="list-style-type: none"> 1) Needle to be replaced by another of proper size. 2) Readjusting the timing to feed dog in respect to the needle. 3) To make both the centre of the hole of the presser foot and the centre of the eyelet of the throat. 4) The positioning & the timing of the needle guard to be taken into account. 5) Relaxing needle thread 6) Appropriate needle to be used.
5	Puckering	<ol style="list-style-type: none"> 1 Thread tension being too high. 2 The problem of the timing of the bobbin thread cam for thread guiding failing to be solved. 3 The problem of surface finish arising from bobbin thread going through the parts on the thread guide. 4 The force on the presser foot being too great. 	<ol style="list-style-type: none"> 1. Decreasing thread tension, esp. tension of bobbin thread. 2. Readjusting of the very cam said to solve the timing problem. 3. Surface finishing all the parts on the thread guide. 4. Turning counter-clockwise the pressure-regulating screw.

零件手冊

PARTS BOOK

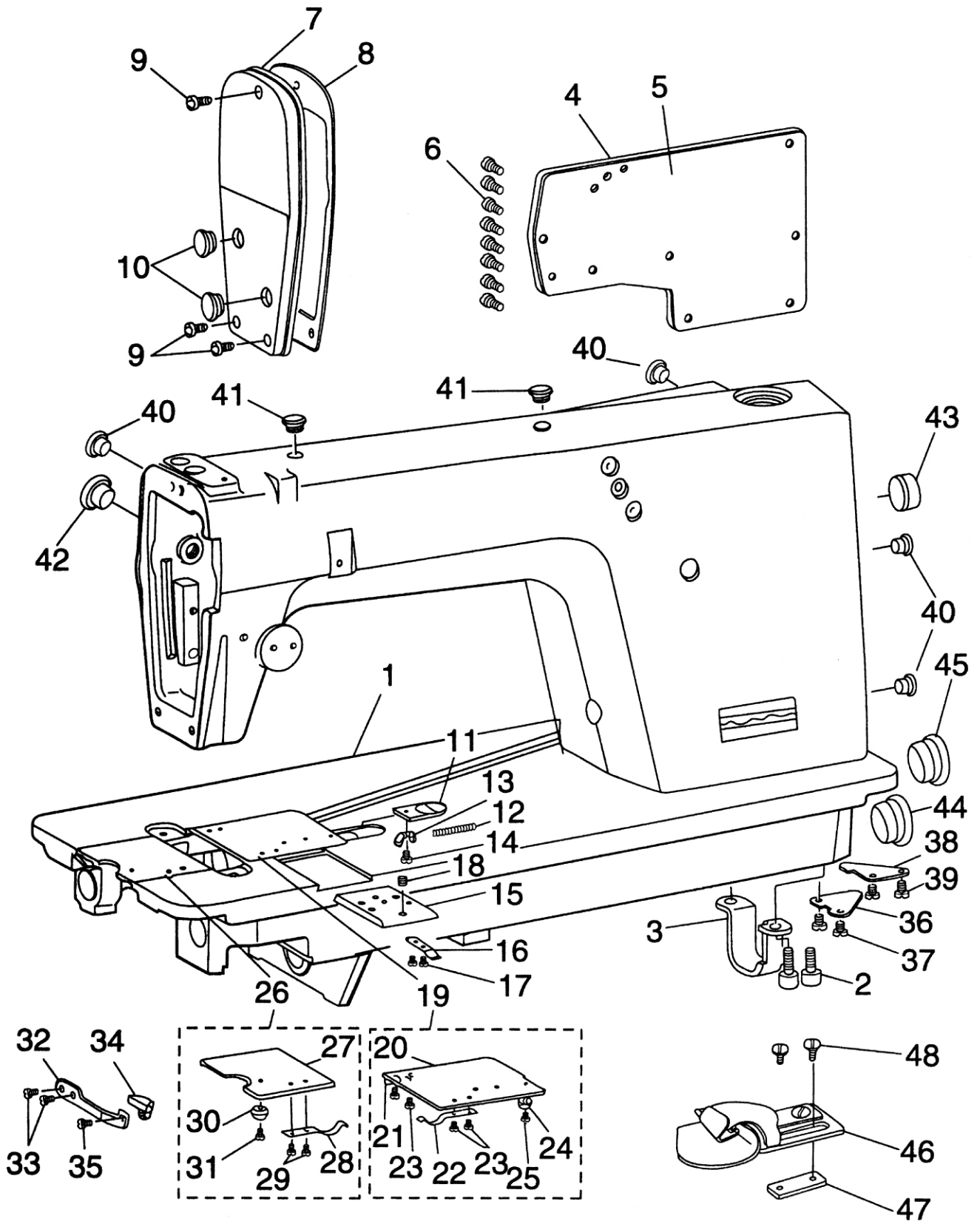

1、机壳分组件

Arm bed components

序号 Ref. No.	件号 Part No	名称	Description	数量 Amt. Req.
1	GQ202/13	机壳部件	Arm bed complete	1
2	GS0127	底板支承螺钉	Bed screw stud	2
3	GR1823	底板支承板	Bed support	1
4	GK186	后窗板	Side plate	1
5	GR1812	后窗板垫	Gasket	1
6	GS100	后窗板螺钉	Side plate screw	8
7	GR1757/2	面板部件	Face plate asm.	1
8	GR1758	面板垫	Face plate gasket	1
9	GS100	面板螺钉	Screw	3
10	GR1458	面板调节镙孔塞	Rubber plug	2
11	GR1813	凸轮盖压板	Cam cover latch	1
12	GW287	凸轮盖压板弹簧	Spring	1
13	GR1814	凸轮盖压板弹簧座	Spring suspension	1
14	GS069	凸轮盖压板座螺钉	Screw	1
15	GM241	附件安装板	Attachment installing plate	1
16	GW288	附件安装板弹簧	Spring	1
17	GS0128	附件安装板弹簧螺钉	Screw	2
18	GS012	附件安装板定位螺钉	Screw	1
19	GM242/9	凸轮盖部件	Cam cover asm	(1)
20	GM243	凸轮盖	Cam cover	1
21	GW289	凸轮盖托板	Cam cover	1
22	GW290	凸轮盖弹簧	Spring	1
23	GS045	凸轮盖弹簧螺钉	Screw	4
24	GR1815	凸轮盖导轮	Cam cover guide	1
25	GS0129	凸轮盖导轮螺钉	Screw	1
26	GM244/6	推板部件	Bed slide asm.	(1)
27	GM245	推板	Bed slide	1
28	GW291	推板簧	Spring	1
29	GS045	推板簧螺钉	Screw	2
30	GR1816	推板导轮	Bed slide guide	1
31	GS0129	推板导轮螺钉	Screw	1
32	GW292	推板锁簧	Bed slide lock spring	1
33	GS010	推板锁簧螺钉	Screw	2
34	GR1817	推板簧把手	Latch	1
35	GS44	推板簧把手螺钉	Screw	1
36	GR1818	送料轴底板挡油板	Bed oil shield	1
37	GS010	底板挡油板螺钉	Screw	2
38	GR1819	抬牙轴底板挡板油板	Bed oil shield	1
39	GS010	底板挡油板螺钉	Screw	2
40	GR1461	轴套定位镙孔塞	Rubber plug	4
41	GR1462	上轴套油线孔塞	Rubber plug	2
42	GR1463	针杆曲柄镙孔塞	Rubber plug	1
43	GR1464	送料针距调节器孔塞	Rubber plug	1
44	GR1465	抬牙轴孔塞	Rubber plug	1
45	GR1466	下轴盲孔塞	Rubber plug	1
46	GR1916/5	卷边器部件(1/4")	Folder	1
47	GR1923	卷边器垫块	Gasket	1
48	GS0148	卷边器螺钉	Screw	2

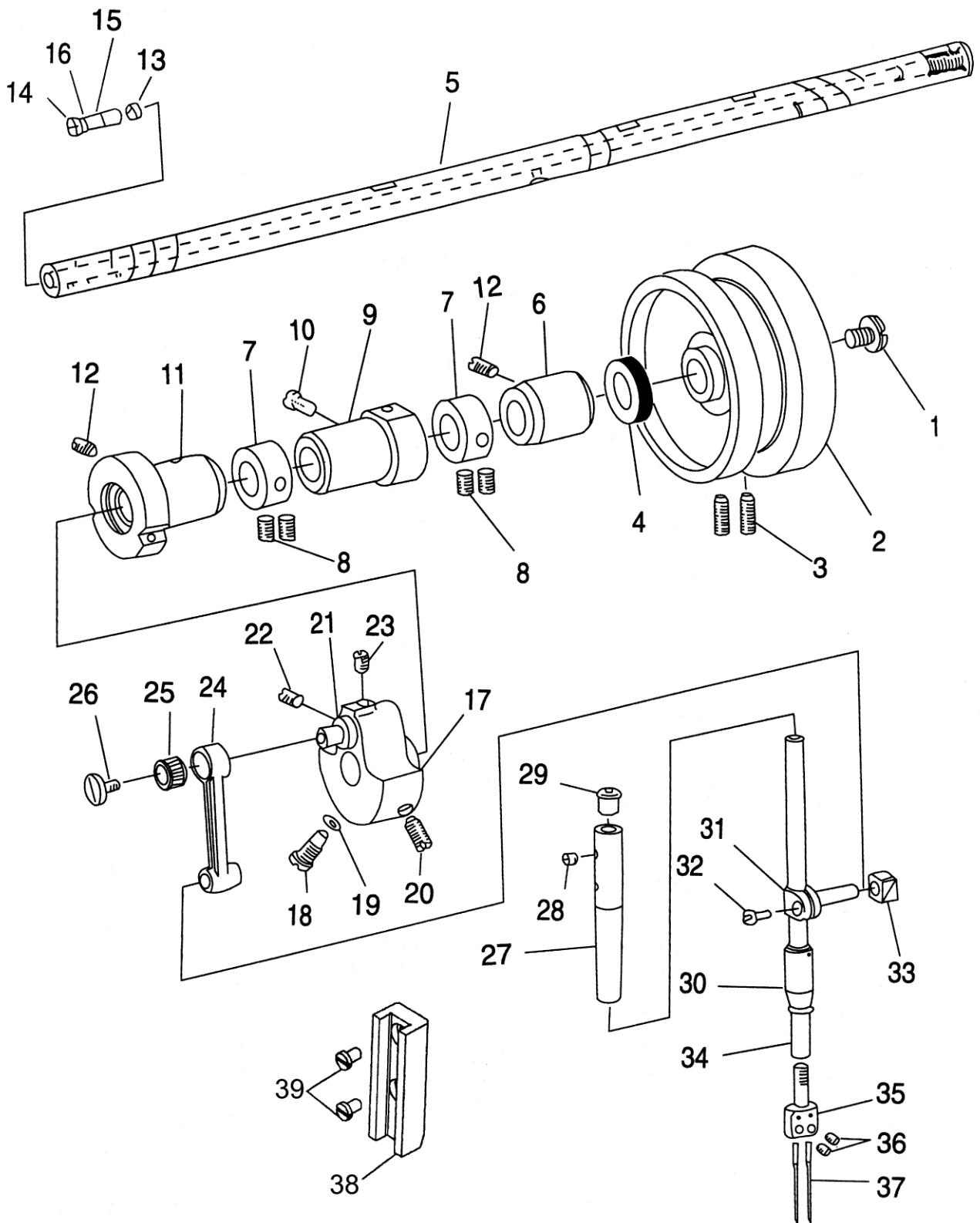

2、上轴针杆分组件

Main shaft & needle bar components

序号 Ref. No.	件号 Part No	名称	Description	数量 Amt. Req.
1	GS02	上轴安全螺钉	End screw	1
2	GP132	上轮	Hand wheel	1
3	GS03	上轮螺钉	Screw	2
4	GR1468/2	上轴油封	Oil seal	1
5	GZ303	上轴	Main shaft	1
6	GO262/2	上轴后轴套部件	Main shaft bushing, rear	1
7	GR1824	上轴挡圈	Main shaft thrust collar	2
8	GS33	上轴挡圈螺钉	Screw	4
9	GO265-1	上轴中轴套部件	Main shaft bushing intermediate	1
10	GS05	中轴套螺钉	Screw	1
11	GO303/2	上轴前轴套部件	Main shaft bushing, front	1
12	GS04	轴套螺钉	Screw	2
13	GR1470	曲柄油量限制毡	Roller felt	1
14	GX334	曲柄油量调节销	Crank oil adjusting pin	1
15	GO269	曲柄油量调节销套	Rubber bushing	1
16	GR1471	曲柄油量调节销O形圈	O-Rubber ring	1
17	GH378	针杆曲柄	Counterweight asm.	1
18	GS06	针杆曲柄定位螺钉	Screw	1
19	GR1472	定位螺钉O形圈	O-Rubber ring	1
20	GS07	针杆曲柄紧固螺钉	Screw	1
21	GH379	针杆连杆销	Needle crank	1
22	GS48	挑线曲柄定位螺钉	Screw	1
23	GS041	挑线曲柄螺钉	Screw	1
24	GH334	针杆连杆	Needle bar crank rod	1
25	GO270	针杆连杆滚针轴承	Needle roller bearing	1
26	GS09	针杆连杆左旋螺钉	Left twist screw	1
27	G0271	针杆上衬套	Needle bar bushing upper	1
28	GS012	针杆上衬套螺钉	Screw	1
29	GR1479	针杆上衬套孔塞	Rubber plug	1
30	GO288	针杆下衬套	Needle bar bushing, lower	1
31	GR1478-7	针杆连接柱	Needle bar connection asm	1
32	GS011	针杆连接柱螺钉	Screw	1
33	GU168-7	针杆连接柱滑块	Crank slide block	1
34	GZ304	针杆	Needle bar	1
35	GR1826	针夹 (1/4")	Needle clamp(1/4")	1
36	GS0130	支针螺钉	Screw	2
37	GV18	机针	Needle	2
38	GR0341-7	针杆接头滑块导轨	Slide block bushing	1
39	GS766	滑块导轨螺钉	Screw	2

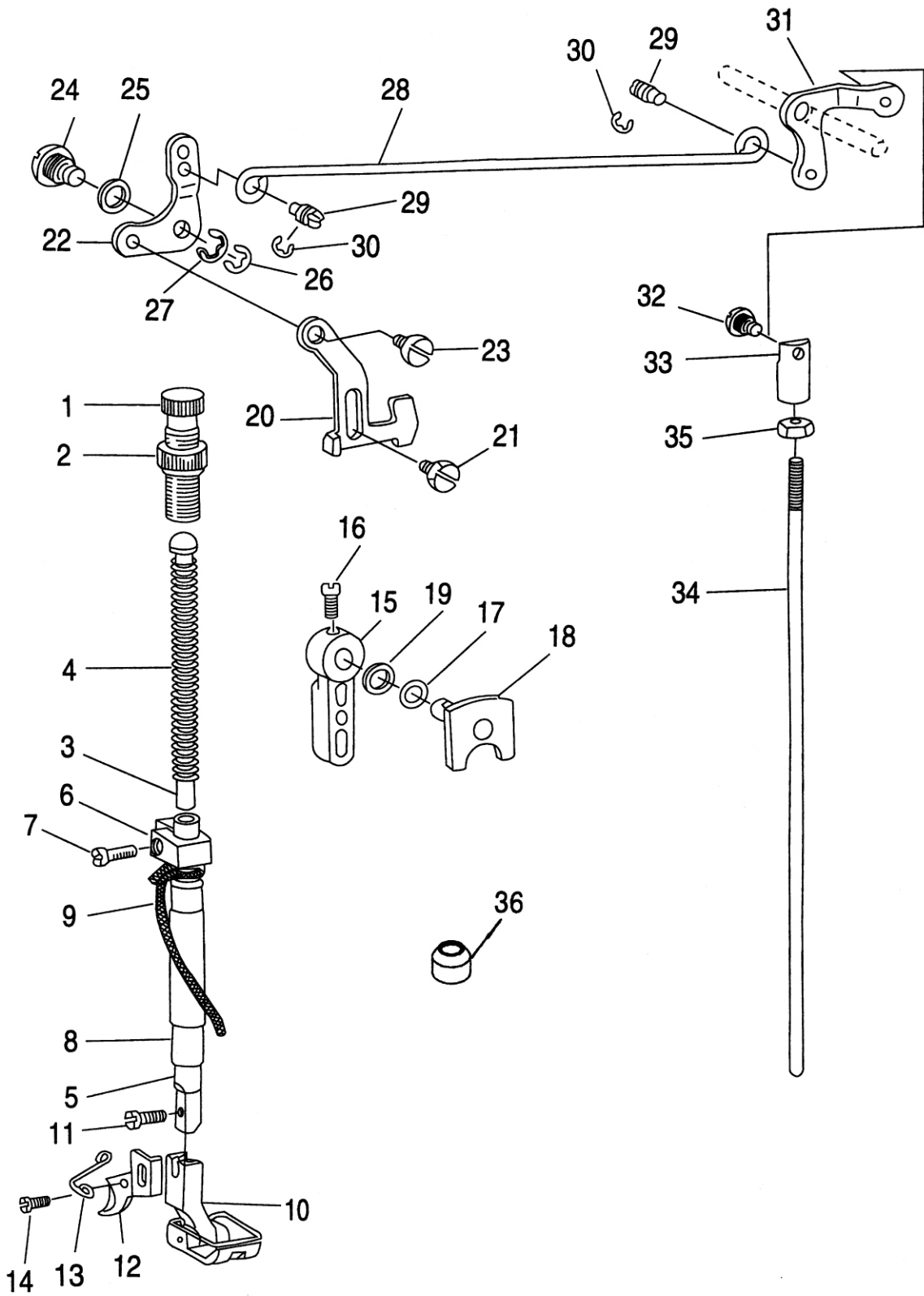

3、压料分组件

Presser bar components

序号	件号	名称	Description	数量
Ref. No.	Part No			Amt. Req.
1	GS018	调压螺钉	Presser spring regulator	1
2	GL18	调压螺钉螺母	Nut	1
3	GR1494	调压导杆	Presser bar guide bar	1
4	GW253	调压簧	Presser spring	1
5	GZ305	压杆	Presser bar	1
6	GR1827	压杆导架	Presser bar guide bracket asm.	1
7	GS019	压杆导架螺钉	Screw	1
8	GO273	压杆衬套	Presser bar bushing,lower	1
9	GR1525	压杆油线	Oil wick	1
10	GM246/5	压脚部件1/4"	Presser foot asm.	1
11	GS020	压脚螺钉	Screw	1
12	GR1832	切线刀	Thread knife	1
13	GR1833	切线刀导钩	Thead knife guide	1
14	GS0129	切线刀导钩螺钉	Screw	1
15	GR1499	压脚扳手	Hand lifter	1
16	GS021	压脚扳手螺钉	Screw	1
17	GR1500	压脚扳手垫圈	Washer	1
18	GR1501/2	压脚扳手凸轮部件	Hand lifter cam asm.	1
19	GR1503	压脚扳手轴O形圈	Rubber ring	1
20	GR1504	压脚升降板	Lifting lever	1
21	GS022	升降板轴位螺钉	Hinge screw	1
22	GR1505	抬压脚前杠杆	Lifting link for lifting lever	1
23	GS023	前杠杆轴位螺钉	Hing screw	1
24	GS024	前杠杆螺纹销	Hinge pin	1
25	GR1506	前杠杆螺纹销垫圈	Lifting lever gasket	1
26	GR1508	前杠杆特制开口挡圈	Snap ring	1
27	GR1507	前杠杆开口挡圈	Snap ring	1
28	GR1834	抬压脚拉杆	Lifting lever connecting rod	1
29	GS025	抬压脚拉杆螺钉	Screw	2
30	GR1510	抬压脚拉杆开口挡圈	Snap ring	2
31	GR1835	抬压脚后杠杆	Lifting lever link rear	1
32	GS0131	后杠杆轴位螺钉	Hinge screw	1
33	GR1836	抬压脚顶杆接头	Swivel	1
34	GX378	抬压脚顶杆	Lifting lever connecting rod,vertical	1
35	GL19	抬压脚顶杆螺钉	Nut	1
36	GR1353-7	压杆密封套	Rubber rule	1

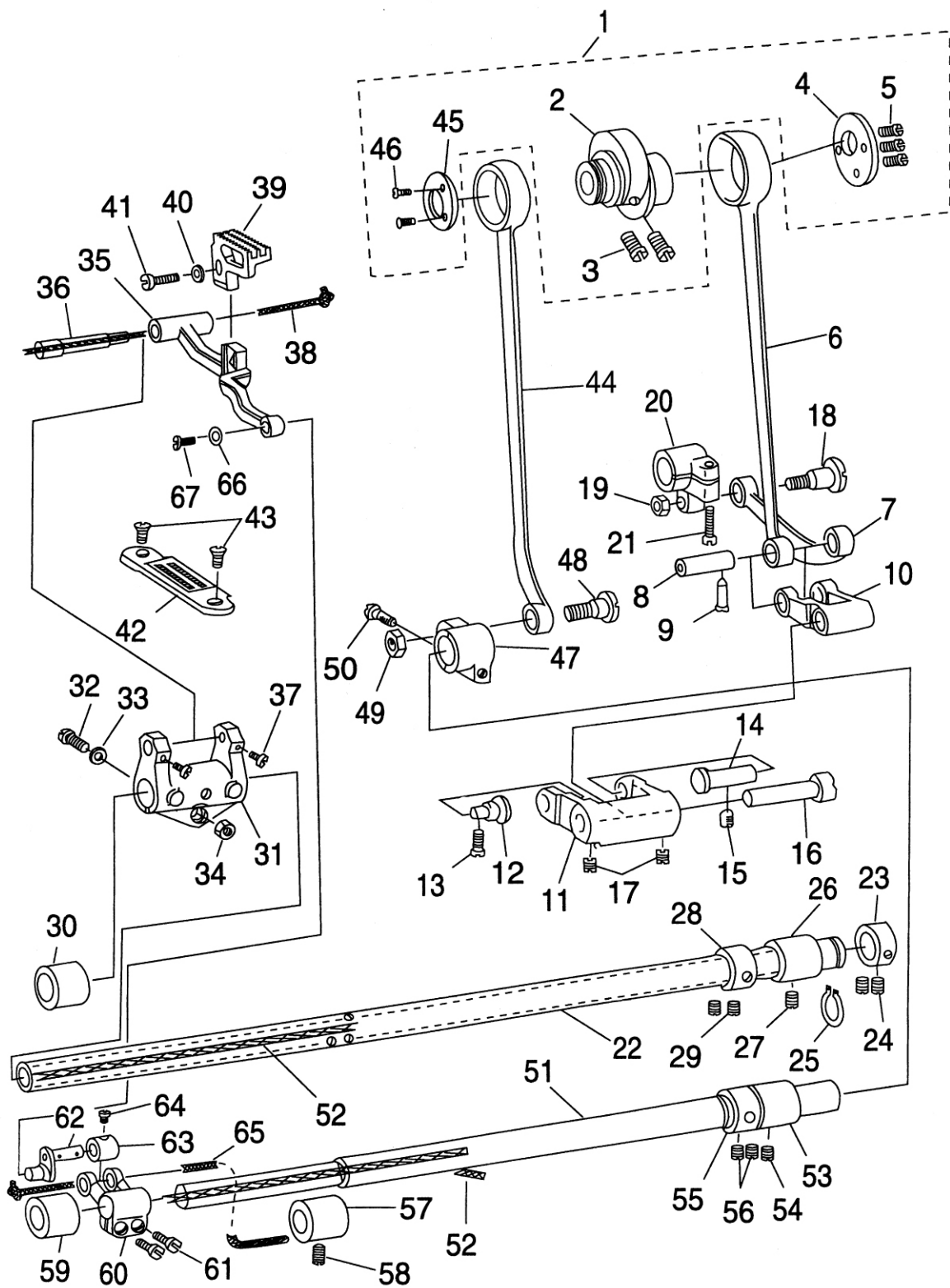

4、送料分组件 Feed mechanism components

序号 Ref. No.	件号 Part No	名称	Description	数量 Amt. Req.
1	GT160/10	送料偏心轮部件	Feed eccentric cam asm.	1
2	GT161	送料偏心轮	Feed eccentric cam	1
3	GS034	送料偏心轮螺钉	Screw	2
4	GR1521	送料偏心轮盖板	Feed eccentric thrust washer	1
5	GS035	偏心轮盖板螺钉	Screw	3
6	GH335	送料大连杆	Feed rocker shaft connecting rod	1
7	GH380	送料小连杆	Connecting rod	1
8	GX340	送料连杆销	Connecting pin	1
9	GS036	送料连杆销螺钉	Screw	1
10	GR1522	送料摆杆	Feed driving rocker asm.	1
11	GR1523	送料摆杆座	Feed driving rocker	1
12	GX341	送料摆杆座右销	Hinge stud	1
13	GS037	送料摆杆座右销螺钉	Screw	1
14	GX342	送料摆杆座右销	Hinge pin	1
15	GS05	送料摆杆座右销螺钉	Screw	1
16	GZ279	送料摆杆销	Hinge pin	1
17	GS038	送料摆杆销螺钉	Screw	2
18	GS039	送料曲柄轴位螺钉	Hinge screw	1
19	GL7	送料曲柄轴位螺母	Nut	1
20	GH337	送料曲柄	Feed rocker shaft crank	1
21	GS040	送料曲柄螺钉	Screw	1
22	GZ280	送料轴	Feed rocket shaft	1
23	GR1890	送料轴薄挡圈	Thrust collar	1
24	GS032	送料轴薄挡圈螺钉	Screw	2
25	GR1524	送料轴轴用挡圈	Retaining ring	1
26	GO285	送料轴后轴套	Bushing rear	1
27	GS41	送料轴后轴套螺钉	Screw	1
28	GR1469	送料轴挡圈	Thrust collar	1
29	GS39	送料轴挡圈螺钉	Screw	2
30	GO286	送料轴前轴套	Feed rocker shaft bushing,front	1
31	GR1838	牙架座	Feed rocker	1
32	GS0120	牙架座螺钉	Screw	1
33	GR1528	牙架座螺钉垫圈	Washer	1
34	GL20	牙架座螺钉螺母	Nut	1
35	GR1839	牙架	Feed bar	1
36	GX396	牙架销	Feed bar shaft	1
37	GS0100	牙架销螺钉	Screw	2
38	GR1837	牙架销油线	Oil wick	1
39	GM247	送料牙1/4"	Feed dog (1/4)	1
40	GR1528	送料牙垫圈	Washer	1
41	GS019	送料牙螺钉	Screw	1
42	SM248	针板1/4"	Throat plate(1/4)	1
43	GS044	针板螺钉	Screw	2
44	GH381	拾牙连杆	Feed driving shaft connecting rod	1
45	GR1840	拾牙连杆凸轮盖	Feed driving eccentric thrust washer	1
46	GS0115	拾牙连杆凸轮盖螺钉	Screw	2
47	GH397	拾牙后曲柄	Feed driving shaft crank rear	1
48	GS039	拾牙连杆轴位螺钉	Hinge screw	1
49	GL7	拾牙连杆轴位螺母	Nut	1
50	GS040	拾牙后曲柄紧固螺钉	Screw	1
51	GZ306	拾牙轴	Feed driving shaft	1
52	GR1837	拾牙轴油线	Oil wick	2
53	GO285	拾牙轴后轴套	Bushing, rear	1
54	GS48	拾牙轴后轴套螺钉	Screw	1
55	GR1469	拾牙轴后轴套挡板	Thrust collar	1
56	GS39	后轴套挡圈螺钉	Screw	2
57	GO300	拾牙轴中轴套	Bushing, intermediate	1
58	GS04	拾牙轴中轴套螺钉	Screw	1
59	GO306	拾牙轴前轴套	Feed rocker shaft bushing, front	1
60	GH382	拾牙轴前曲柄	Feed rocker shaft crank	1
61	GS0132	拾牙轴前曲柄螺钉	Screw	2
62	GH383	牙架连杆	Feed bar link	1
63	GR1841	牙架连杆挡圈	Thrust collar	1
64	CS013	牙架连杆挡圈螺钉	Screw	1
65	GR1837	牙架连杆油线	Oil wick	1
66	GR1842	牙架连杆锥孔垫圈	Counter-sunk washer	1
67	GS0133	牙架连杆垫圈螺钉	Screw	1

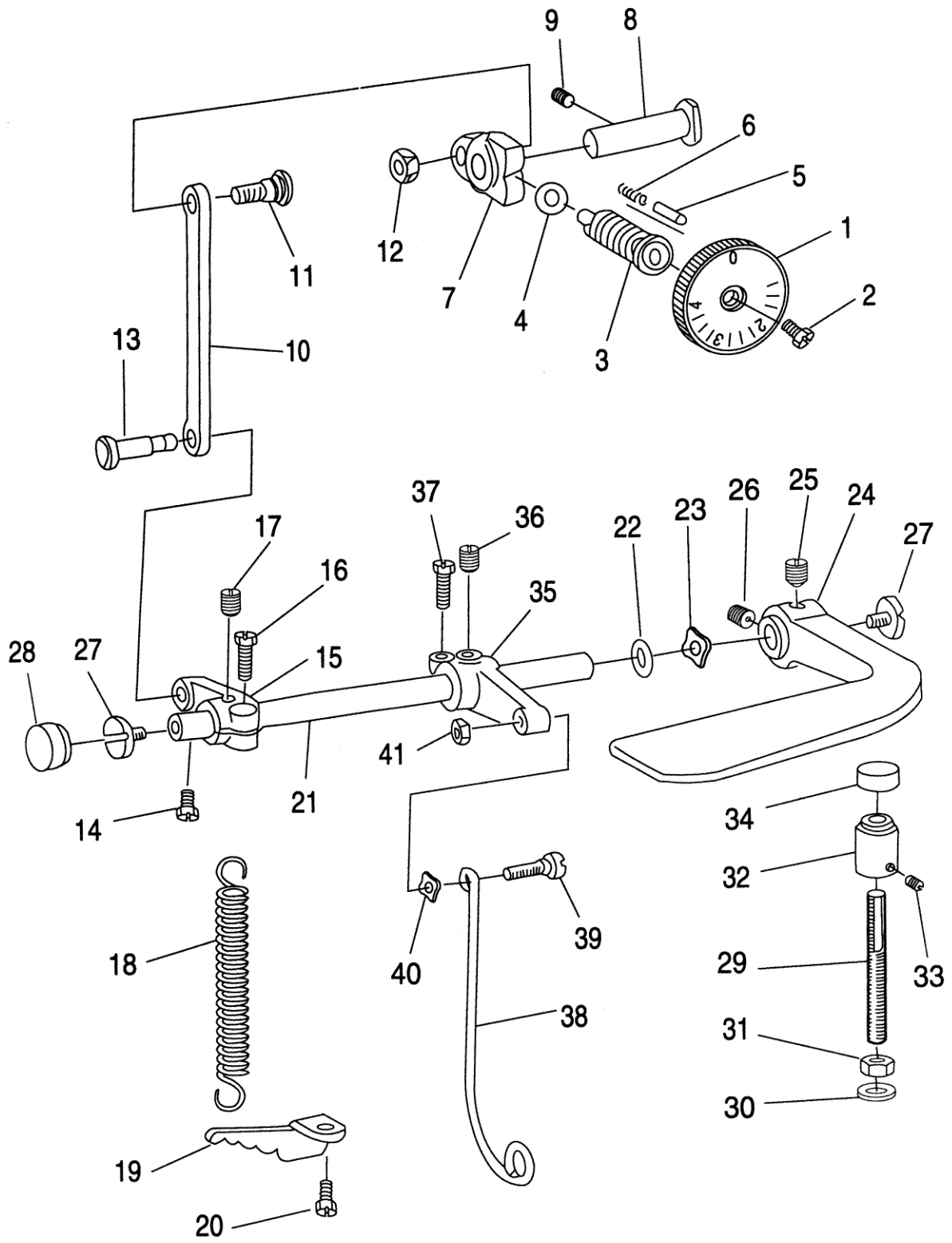

5、送料调节分组件

Feed regulating components

序号 Ref. No.	件号 Part No	名称	Description	数量 Amt. Req.
1	GS1536/3	送料距旋钮部件	Stitch dial asm.	1
2	GS046	送料距旋钮螺钉	Screw	1
3	GS047	送料调节螺柱	Feed regulating screw	1
4	GR1538	送料调节螺柱O形圈	O-Rubber ring	1
5	GX345	送料距锁合销	Stitch dial lock pin	1
6	GW257	送料距锁合销簧	Stitch dial lock spring	1
7	GR1843	送料调节器	Feed regulator	1
8	GX346	送料调节器销	Hinge pin	1
9	GS48	送料调节器销螺钉	Screw	1
10	GH341	送料调节器连杆	Feed regulator connecting rod	1
11	GS048	调节器连杆轴位螺钉	Hingr screw	1
12	GL20	调节器连杆轴位螺母	Nut	1
13	GR1540	拉簧调节曲柄销	Tension spring suspension stud	1
14	GS100	拉簧调节曲柄销螺钉	Screw	1
15	GH342	拉簧调节曲柄	Tension spring suspension crank	1
16	GS049	调节曲柄紧固螺钉	Clamp screw	1
17	GS48	调节曲柄定位螺钉	Screw	1
18	GW258	倒送料轴拉簧	Tension spring	1
19	GR1547	拉簧固定板	Suspension bracket	1
20	GS01	拉簧固定板螺钉	Screw	1
21	GZ282	倒送料轴	Reverse feed control lever shaft	1
22	GR1542	倒送料轴O形圈	Rubber ring,large	1
23	GS1543	倒送料轴弹性垫圈	Waved washer	1
24	GR1544	倒送料扳手	Reverse feed control lever	1
25	GS050	倒送料扳手定位螺钉	Screw	1
26	GS033	倒送料扳手螺钉	Screw	1
27	GS051	倒送料轴端螺钉	End screw	2
28	GR1545	倒送料轴端孔塞	Rubber plug	1
29	GS0134	倒送料挡块螺杆	Screw	1
30	GR1599	档块螺杆垫圈	Washer	1
31	GL21	挡块螺杆螺母	Nut	1
32	GR1844	倒送料挡块	Lever stopper	1
33	GS0135	倒送料挡块螺钉	Screw	1
34	GR1845	倒送料挡块橡胶垫	Rubber cushion	1
35	GH344	倒送料曲柄	Control lever crank,rear	1
36	GS48	倒送料曲柄定位螺钉	Screw	1
37	GS049	倒送料曲柄螺钉	Screw	1
38	GH345	倒送料连杆	Feed driving rocker arm connecting	1
39	GS052	倒送料连杆轴位螺钉	Screw	1
40	GR1546	倒送料连杆轴位垫圈	Washer	1
41	GL20	倒送料连杆轴位螺母	Nut	1

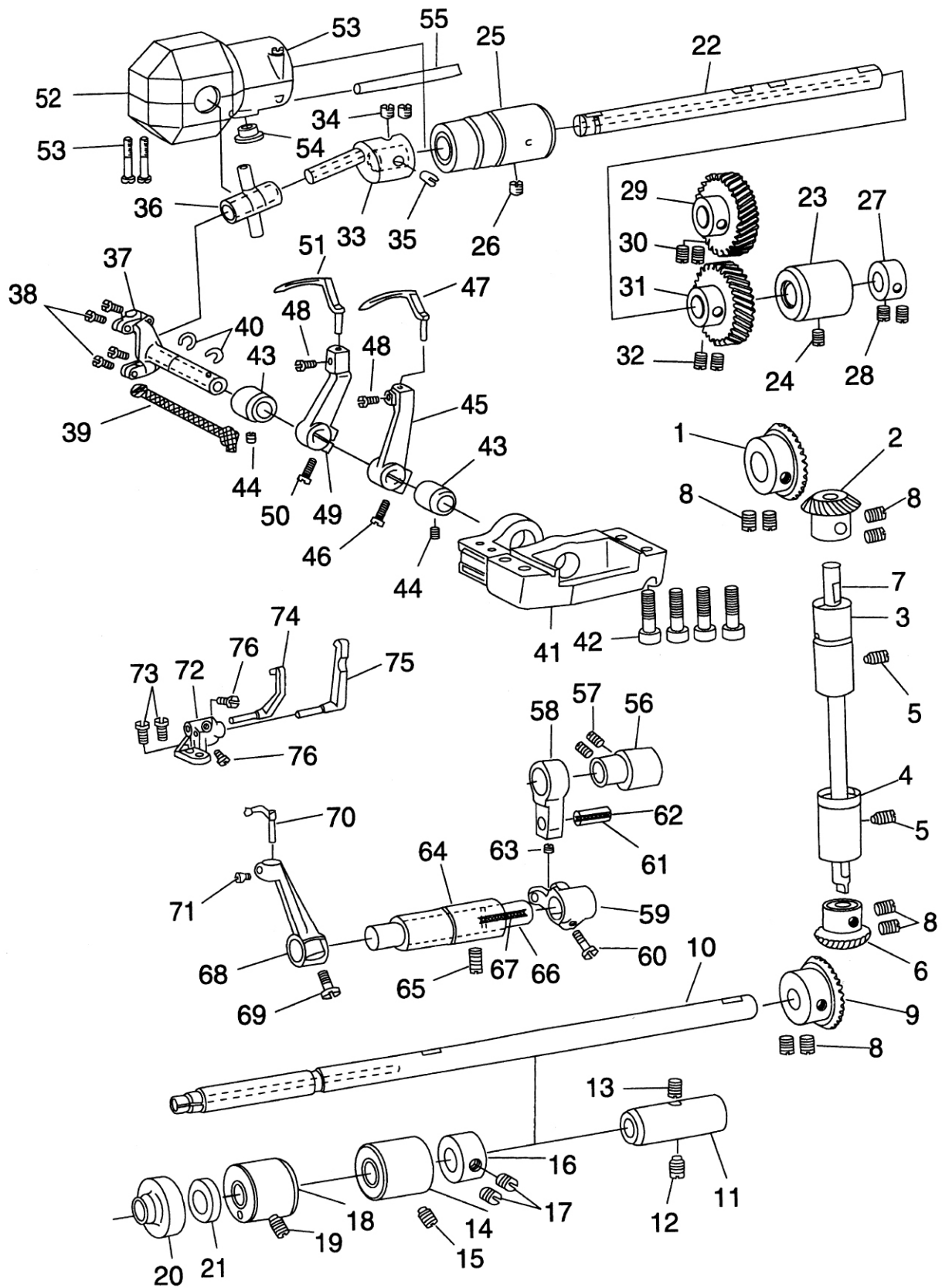

6、弯针勾线分组件

Looper thread retainer components

序号	件号	名称	Description	数量
Ref. No.	Part No			Amt. Req.
1	GC168	上轴伞齿轮	Gear asm.	1
2	GC167	竖轴上伞齿轮	Pinion asm.	1
3	GO283	竖轴上轴套	Bushing,upper	1
4	GO280/2	竖轴下轴套部件	Bushing,lower	1
5	GS04	竖轴轴套螺钉	Screw	2
6	GC167	竖轴下伞齿轮	Gear asm.	1
7	GZ307-1	竖轴	Upright, shaft	1
8	GS033	伞齿轮螺钉	Bushing, front asm,screw	8
9	GC169	下轴伞齿轮	Gear asm	1
10	GZ308	下轴	Lower shaft asm.	1
11	GO307	下轴后轴套	Bushing, rear	1
12	GS04	下轴后轴套螺钉	Screw	1
13	GR1847	下轴后轴套油毡	Felt	1
14	GO308/2	下轴中轴套部件	Bushing,intermediate	1
15	GS04	下轴中轴套螺钉	Screw	1
16	GR1848	下轴挡圈	Thrust collar asm	1
17	GS033	下轴挡圈螺钉	Screw	2
18	GO311/2	下轴轴套部件	Bushing,front	1
19	GS04	下轴轴套螺钉	Screw	1
20	GR1849	下轴前轴套油封套	Looper thread guard bushing	1
21	GR1850	下轴前轴套油封	Oil seal	1
22	GZ309	弯针轴	Looper rocker shaft	1
23	GO308/2	弯针轴后轴套部件	Bushing,intermediate	1
24	GS04	弯针后轴套螺钉	Screw	1
25	GO314/2	弯针轴前轴套部件	Bushing,front	1
26	GS48	弯针轴前轴套螺钉	Screw	1
27	GR1848	弯针轴挡圈	Thrust collar asm	1
28	GS033	弯针轴挡圈螺钉	Screw	2
29	GC170	主动弯针齿轮	Gear asm.upper	1
30	GS033	主动弯针齿轮螺钉	Screw	2
31	GC171	被动弯针齿轮	Gear asm.lower	1
32	GS033	被动弯针齿轮螺钉	Screw	2
33	GH384	弯针曲柄	Looper crank asm.	1
34	GS033	弯针曲柄螺钉	Screw	2
35	GS0136	弯针曲柄调节螺钉	Looper crank adjusting screw	1
36	GR1851/5	弯针十字接头部件	Trunnion asm.	1
37	GZ310/3	弯针摆轴部件	Looper rocker shaft asm	1
38	GS0100	弯针摆轴盖螺钉	Screw	4

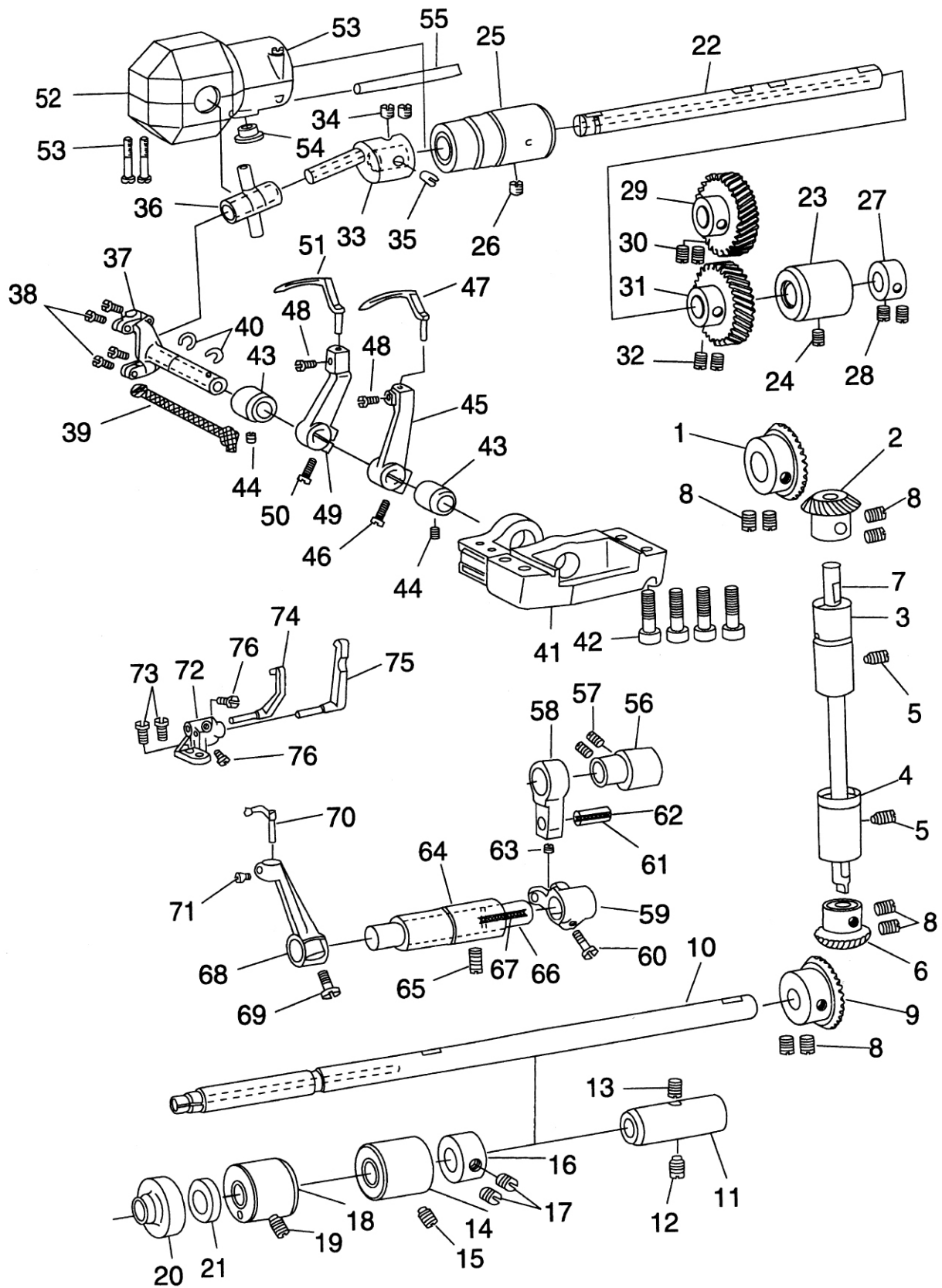

6、弯针勾线分组件

Looper thread retainer components

序号 Ref. No.	件号 Part No	名称	Description	数量 Amt. Req.
39	GR1837	弯针摆轴油线	Oil wick	1
40	GR1854	弯针摆轴挡圈	Snap ring	2
41	GR1855	弯针架座	Looper mounting base	1
42	GS0137	弯针架座螺钉	Screw	4
43	GO318	弯针摆轴轴套	Bushing, rear	2
44	GS032	弯针摆轴轴套螺钉	Screw	2
45	GH385	左弯针曲柄	Looper holder asm.(left)	1
46	GS040	左弯针曲柄螺钉	Screw	1
47	GN169	左弯针	Looper (left)	1
48	GS0138	弯针螺钉	Screw	2
49	GH386	右弯针曲柄	Looper holder asm. (right)	1
50	GS040	右弯针曲柄螺钉	Screw	1
51	GN170	右弯针	Looper (right)	1
52	GK187/7	弯针曲柄罩壳部件	Crank cover asm	1
53	GS0139	曲柄罩壳螺钉	Screw	3
54	GR1462	曲柄罩壳孔塞	Rubber plug	1
55	GR1856	曲柄罩壳排油管	Vinyl tube	1
56	GT162	护针凸轮	Needle guard crank asm	1
57	GS48	护针凸轮螺钉	Screw	2
58	GH387	护针连杆	Needle guard crank rod	1
59	GH388	护针叉形曲柄	Rear needle guard rocker fork	1
60	GS019	护针叉形曲柄螺钉	Screw	1
61	GX380	护针曲柄销	Pin	1
62	GR1837	护针曲柄销油线	Oil wick	1
63	GS032	护针曲柄销螺钉	Screw	1
64	GO319	护针轴套	Bushing	1
65	GS48	护针轴套螺钉	Screw	1
66	GZ312	护针轴	Needle guard driving shaft asm	1
67	GR1837	护针轴油线	Oil wick	1
68	GH389	护针曲柄	Rear needle guard rocker arm asm.	1
59	GS040	护针曲柄螺钉	Screw	1
70	GR1857	摆动护针(1/4")	Driving needle guard(1/4")	1
71	GS0100	摆动护针杆螺钉	Screw	1
72	GR1858	护针杆座	Needle guard base	1
73	GS030	护针杆座螺钉	Screw	2
74	GR1859	左固定护针杆	Counter needle guard, left	1
75	GR1860	右固定护针杆	Counter needle guard, right	1
76	GS011	左右固定护针杆螺钉	Screw	2

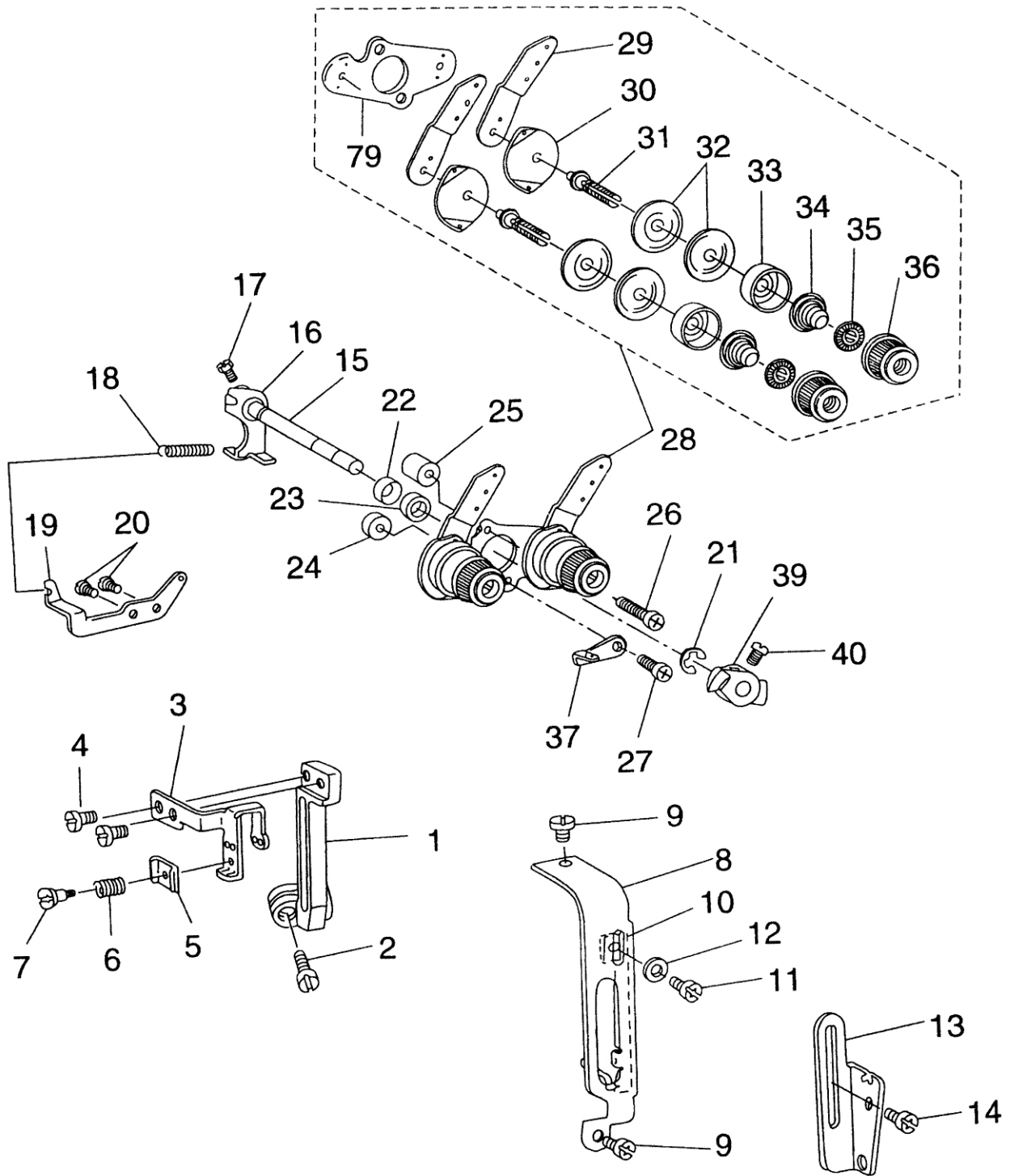

7、挑线、松线、夹线分组件

Thread take-up, tension, and tension releasing assembly complete

序号 Ref. No.	件号 Part No	名称	Description	数量 Amt. Req.
1	GH390	挑线连杆	Thread take-up lever	1
2	GS0140	挑线连杆螺钉	Screw	1
3	GH392	挑线杆	Thread take-up	1
4	GS011	挑线杆紧固螺钉	Screw	2
5	GR1861	挑线杆夹线板	Tension plate	1
6	GW294	挑线杆夹线簧	Tension spring	1
7	GS0141	挑线杆夹线板轴螺钉	Screw	1
8	GK190	挑线杆护罩	Thread take-up lever guard	1
9	GS010	挑线杆护罩螺钉	Screw	2
10	GR1862	线量调节板	Take-up thread tension lever	1
11	GS010	线量调节板螺钉	Screw	1
12	GR1528	调节板螺钉垫圈	Washer	1
13	GR1863	中间导线钩	Frame thread eyelet	1
14	GS010	中间导线钩螺钉	Screw	1
15	GZ313	松线轴	Tension release shaft	1
16	GH393/2	面线松线曲柄部件	Tension release arm asm.	1
17	GS082	面线松线曲柄螺钉	Screw	1
18	GW295	抬压脚后杠杆弹簧	Spring	1
19	GR1865	后杠杆弹簧固定板	Suspension bracket	1
20	GS81	后杠杆弹簧固定板螺钉	Screw	2
21	GR1507	松线轴挡圈	Snap ring	1
22	GR1866	松线轴油封	Oil seal ring	1
23	GR1867	松线轴环	Tension release shaft spacer	1
24	GR1868	夹线器下安装垫	Spacer(A) for installing plate	1
25	GR1869	夹线器上安装垫	Spacer(B) for installing plate	1
26	GS0142	夹线器上安装垫螺钉	Screw	1
27	GS079	夹线器下安装垫螺钉	Screw	1
28	GR1870/19	面线夹线器部件	Needle thread tension asm.	(1)
29	GR1871	面线单面导线板	Needle thread tension guide plate	2
30	GR1872	面线双面导线板	Tension thread guide	2
31	GS0143	夹线螺钉	Looper thread tension post	2
32	GR1488	面线夹线板	Tension disc	4
33	GR1873	面线松线座	Tension disc presser tube	2
34	GW251	面线夹线簧	Tension spring	2
35	GR1490	面线止动板	Tension disc stopper	2
36	GL34/2	面线夹线螺母部件	Tension nut	2
37	GR1875	导线钩	Frame thread guide	2
38	GS010	导线钩螺钉	Screw	1
39	GR1876	面线松线爪	Tension release latch	1
40	GS082	面线松线爪螺钉	Screw	1

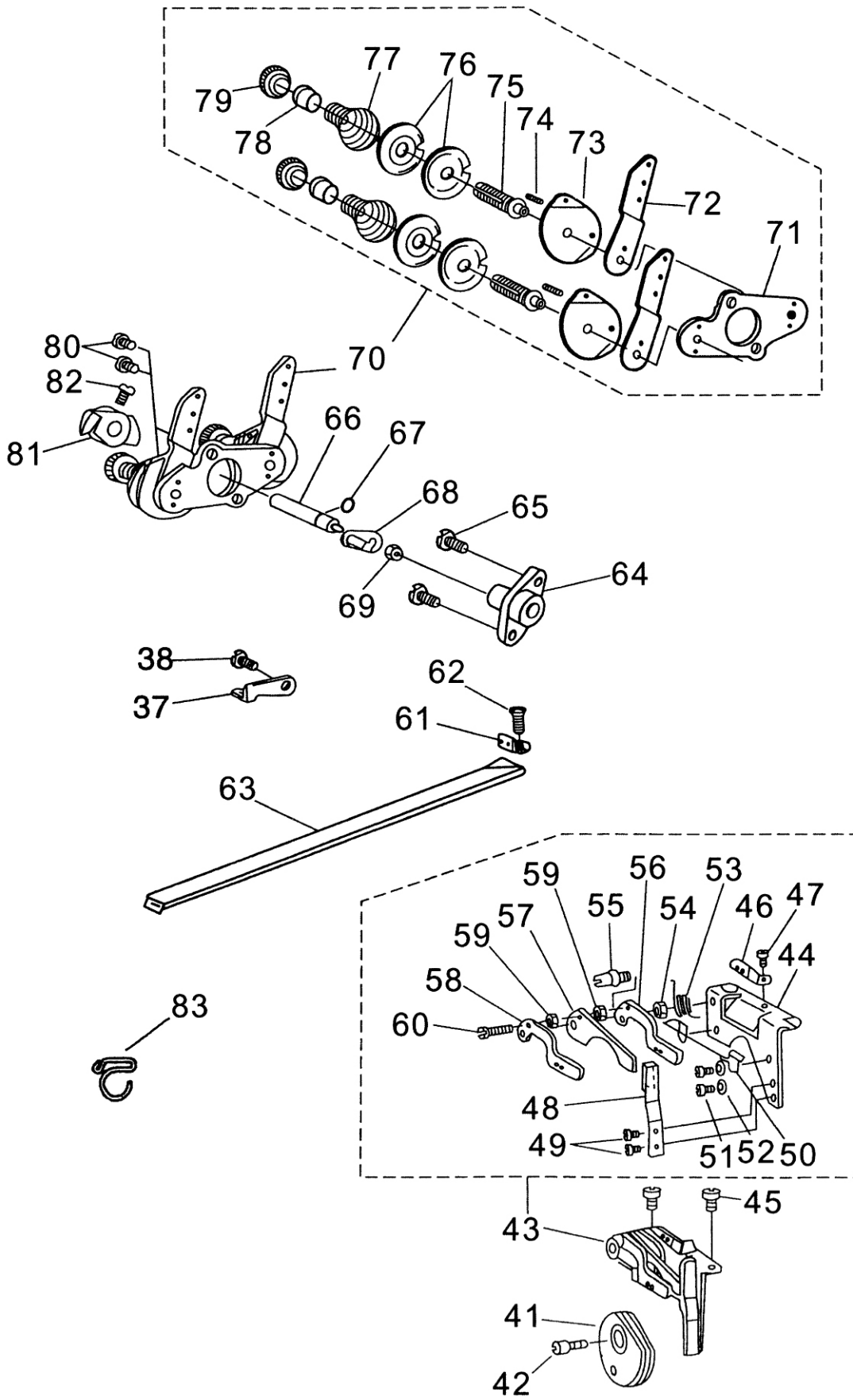

7、挑线、松线、夹线分组件

Thread take-up, tension, and tension releasing assembly complete

序号 Ref. No.	件号 Part No	名称	Description	数量 Amt. Req.
41	GR1877	底线打线凸轮	Looper thread take-up cam	1
42	GS0144	底线打线凸轮定位螺钉	Screw	1
43	GR1878/20	凸轮导线钩部件	Looper thread guide asm.	1
44	GR1879	凸轮导线架	Thread guide plate	1
45	GS010	凸轮导线架螺钉	Screw	2
46	GR1880	底线双线导线钩	Looper thread guide	1
47	GR069	底线双线导线钩螺钉	Screw	1
48	GW296	底线导线止动簧	Thread guide stopper spring	1
49	GS069	底线导线止动簧螺钉	Screw	2
50	GR1881	底线脱线钢丝	Cast-off wire	1
51	GS44	底线脱线钢丝螺钉	Screw	2
52	GR1882	底线脱线钢丝螺钉垫圈	Washer	2
53	GW297	底线导线簧	Thread guide spring	1
54	GL31	凸轮过线螺钉螺母	Nut	1
55	GS0145	凸轮过线螺钉	Thread guide stud	1
56	GR1883	凸轮导线钩（右）	Looper thread guide, right	1
57	GR1884	凸轮脱线爪	Cast-off plate	1
58	GR1885	凸轮导线钩（左）	Looper thread guide, left	1
59	GR1886	凸轮导线环	Collar	2
60	GS065	凸轮导线钩螺钉	Screw	1
61	GR1887	底线导线钩	Looper thread guide	1
62	GS0146	底线导线钩螺钉	Screw	1
63	GR1888	底线导线管	Looper thread guide tube	1
64	GR1889	松线轴套	Tension release shaft bushing	1
65	GS0123	松线轴套螺钉	Screw	2
66	GZ314	底线松线轴	Looper thread release shaft	1
67	GR1800	底线松线轴O型圈	Rubber ring	1
68	GH395/2	底线松线轴曲柄部件	Tension release arm asm.	1
69	GL31	底线松线轴螺母	Nut	1
70	GR1891/19	底线夹线器部件	Lower thread tension asm.	(1)
71	GR1892	夹线器安装板	Tension installing plate	2
72	GR1893	底线单面导线板	Looper thread tension control plate	2
73	GR1894	底线双面导线板	Thread guide	2
74	GX382	底线夹线板止转销	Spring pin	2
75	GS0143	夹线螺钉	Looper thread tension post	2
76	GR1895	底线夹线板	Tension disc	4
77	GW298	底线夹线簧	Looper thread tension spring	2
78	GR1896	底线夹线止转圈	Tension spring bushing	2
79	GL36	底线夹线螺母	Tension post nut	2
80	GS010	夹线器安装板螺钉	Screw	2
81	GR1897	底线松线爪	Looper thread release latch	1
82	GS082	底线松线爪螺钉	Screw	1
83	GS2021	小线钩	Small thread gauge	1

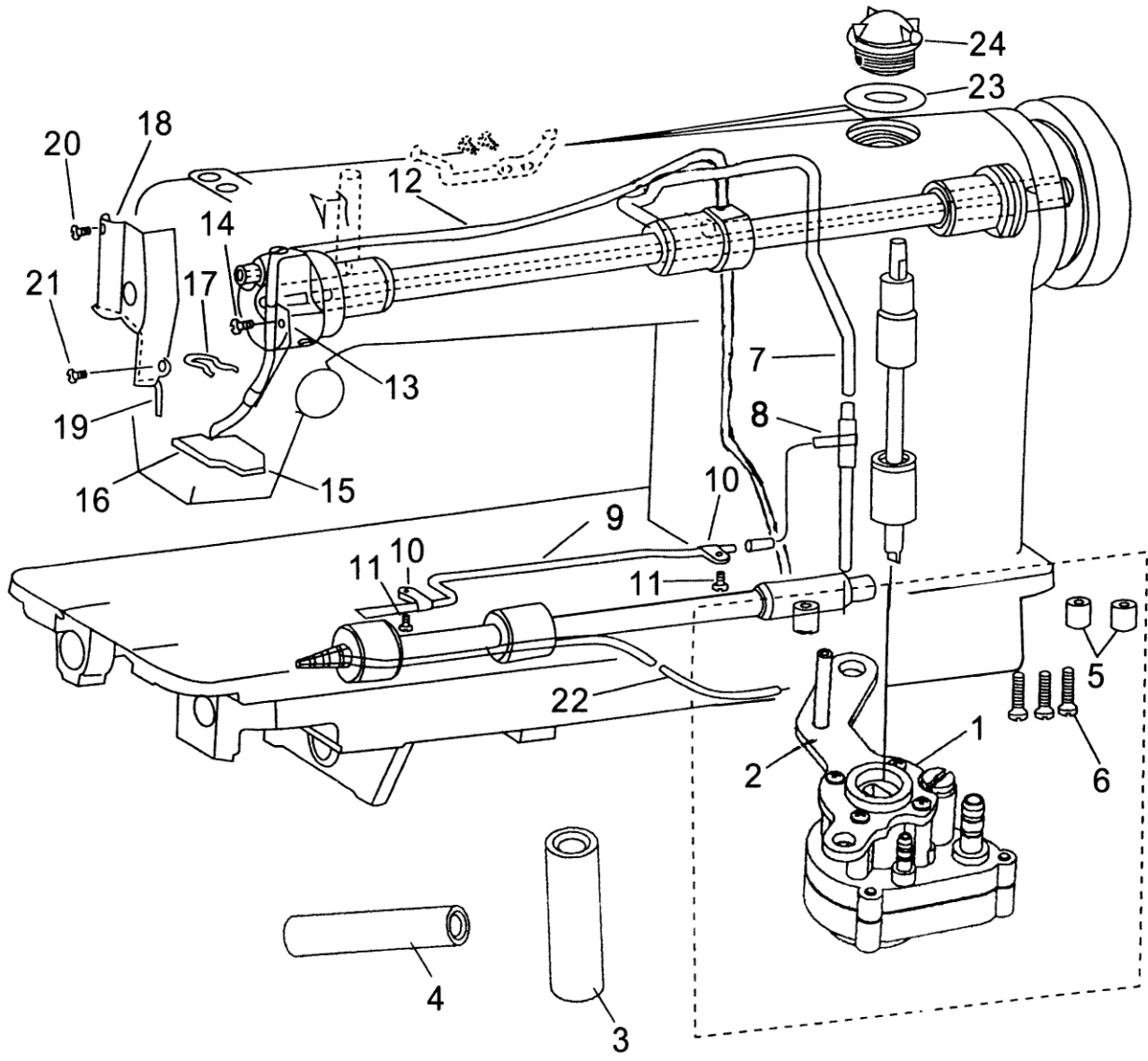

8、润滑分组件 Lubrication

序号 Ref. No.	件号 Part No	名称	Description	数量 Amt. Req.
1	GR1899/21	油泵部件	Lubricating oil pump asm.	(1)
2	GR1549	油泵安装板	Oil pump installing base	1
3	GR1557	上轴供油管接头	Rubber joint	1
4	GR1559	下轴供油管接头	Rubber joint	1
5	GR1901	油泵垫圈	Collar	3
6	GS0109	油泵螺钉	Screw	3
7	GR1902	上轴供油管	Main shaft oil tube	1
8	GR1903	齿轮供油管橡皮接头	Oil sight window base	1
9	GR1904	齿轮供油管	Gear oil pipe	1
10	GR1566	齿轮供油管夹	Holder	2
11	GS81	齿轮供油管夹螺钉	Screw	2
12	GS3401-7	上轴回油管	Oil return tube asm	1
13	GR1566	回油管夹	Oil return tube holder	1
14	GS81	回油管夹螺钉	Screw	1
15	GR1567	回油除尘毡	Oil felt presser	1
16	GR1568	回油毡	Oil felt	1
17	GR1569	回油毡夹	Oil felt presser	1
18	GR1906	面部挡油板	Arm oil shield	1
19	GR1735	面部挡油板油线	Oil wick	1
20	GS069	面部挡油板上螺钉	Screw	1
21	GS010	面部挡油板下螺钉	Screw	1
22	GR1909	下轴供油管	Oil tube	1
23	GR1562	油窗O形圈	O-Rubber ring	1
24	GR1561	油窗	Oil singht window	1

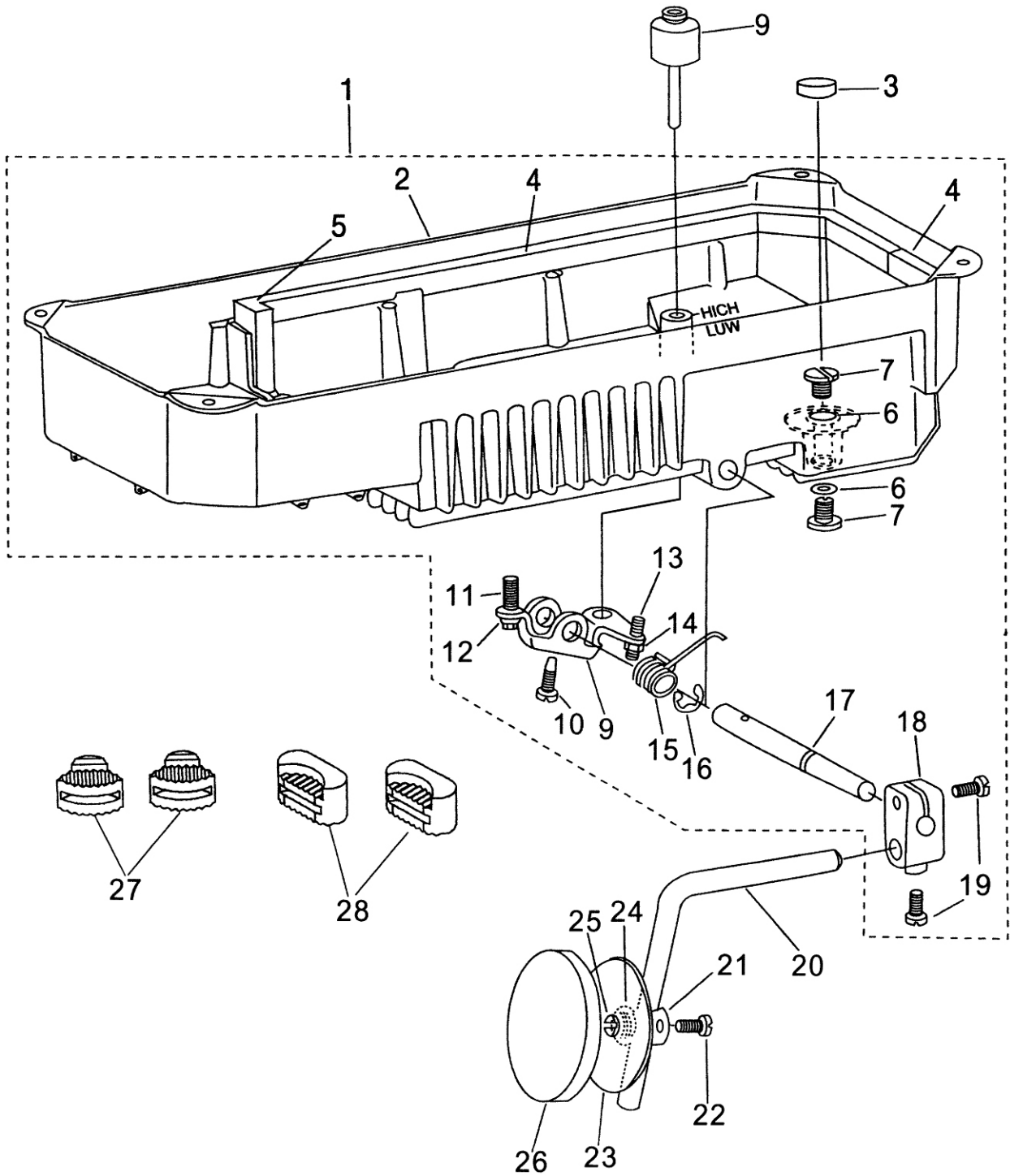

9、油盘、膝抬压脚分组件

Oil reservoir & knee lifter components

序号 Ref. No.	件号 Part No	名称	Description	数量 Amt. Req.
1	GR1910/13	油盘部件	Oil reservoir asm.	(1)
2	GR1911	油盘	Oil reservoir	1
3	GR1576	油盘磁铁	Oil reservoir magnet	2
4	GR1912	油盘侧面垫	Gasket	1
5	GR1913	油盘端面垫	Gasket	2
6	GR1575	排油螺钉O形圈	Oil drain cap gasket	2
7	GS02	排油螺钉	Oil drain screw	1
8	GR1581	抬压脚顶销	Knee press lifter rod	1
9	GR1582	抬压脚双向曲柄	Lifting	1
10	GS056	双向曲柄螺钉	Positioning screw	1
11	GS057	双向曲柄限位螺钉	Positioning screw	1
12	GL21	双向曲柄限位螺母	Nut	1
13	GS058	双向曲柄调节螺钉	Positioning screw	1
14	GL21	双向曲柄调节螺母	Nut	1
15	GW261	双向曲柄扭簧	Spring	1
16	GR1583	抬压脚轴开口挡圈	Thrust ring	1
17	GZ283	抬压脚轴	Knee press rod	1
18	GR1584	抬压脚操纵杆节头	Bearing bracket	1
19	GS059	操纵杆节头螺钉	Clamp screw	2
20	GR1586	操纵杆	Knee lifter plate rod	1
21	GR1587	操纵板节头	Knee predd plate cover joint	1
22	GS08	操纵板节头螺钉	Screw	1
23	GR1588	操纵板	Knee press plate	1
24	GW262	操纵板簧	Knee press plate spring	1
25	GS060	操纵板螺钉	Screw	1
26	GKR13	操纵板软垫	Knee press plate cover	1
27	GR3408-7	小防震垫	Small rubber cushion	2
28	GR1578-7	大防震垫	Big rubber cushion	2

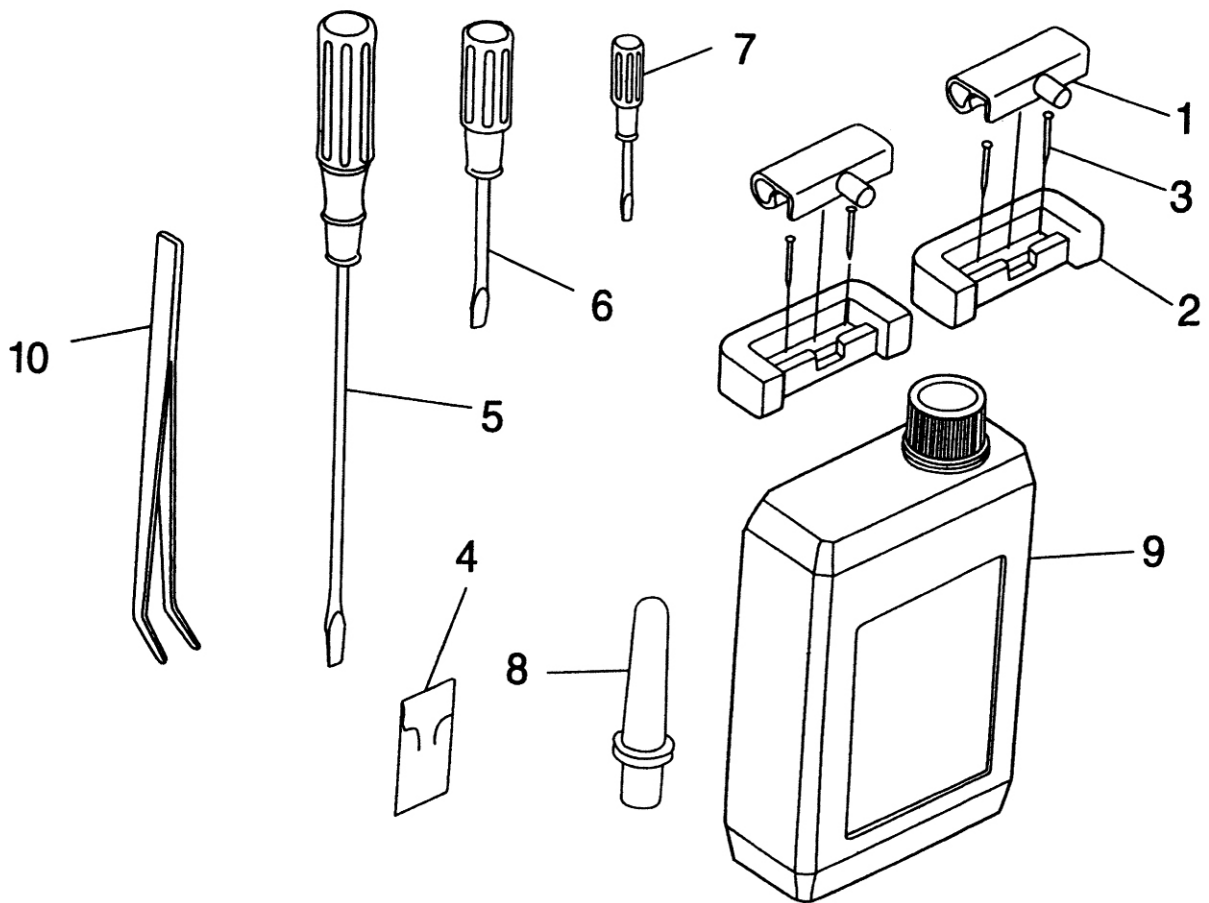
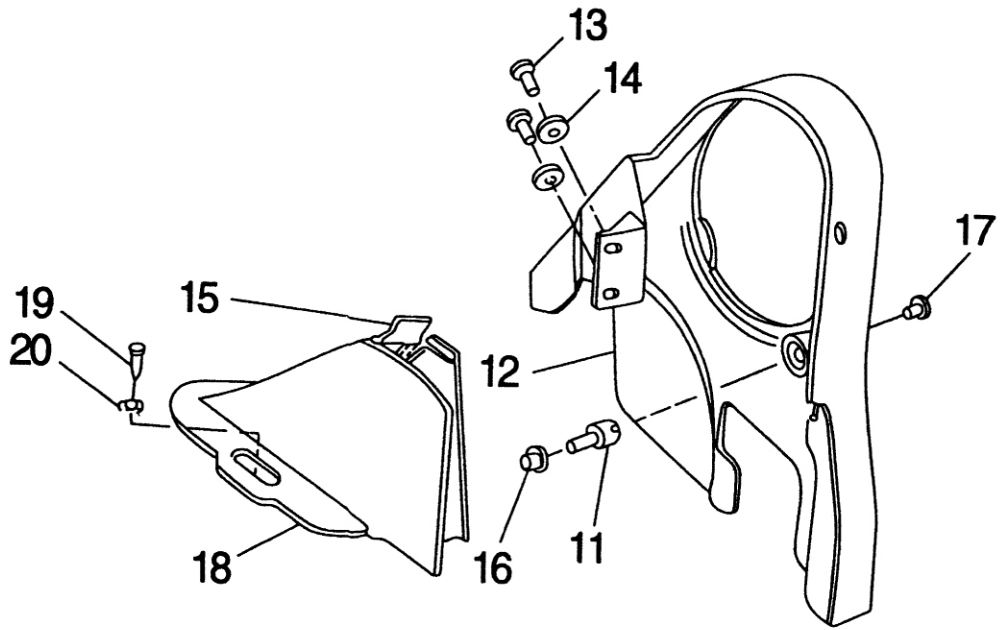

10、机头附件

Machine head accessories

序 号	件 号	名 称	Description	数 量
Ref. No.	Part No			Amt. Req.
1	GR1590/2	机头连接钩部件	Machine hinge plate asm.	2
2	GR1593	机头连接钩座	Machine hinge plate	2
3	GBX105	机头连接钩座钉	Nail	4
4	GV18	机针	Needle	1包
5	GR1601	螺丝刀(大)	Screw driver (L)	1
6	GR1602	螺丝刀(中)	Screw driver (M)	1
7	GR1603	螺丝刀(小)	Screw driver (S)	1
8	GBR148	机头支柱	Machine reat pin	1
9	GR1604/3	油箱部件	Lubricating unit case asm.	1
10	GR558/2	镊子	Tweezer	1
11	GS061	罩壳支柱	Belt cover support stud	1
12	GR1447	上轮前罩壳	Belt-cover A	1
13	GS062	罩壳螺钉	Screw	2
14	GR1599	罩壳螺钉垫圈	Washer	2
15	GR1448	后罩壳盖	Belt-cover B cover asm.	1
16	GL38	后罩支柱螺母	Nut	1
17	GS0574	前罩壳紧固螺钉	Screw	1
18	GR1449	上轮后罩壳	Belt-cover B	1
19	GBS120	传动带罩壳木螺钉	Driving belt cover wood screw	2
20	GBR147	罩壳木螺钉垫圈	Wood screw washer	2

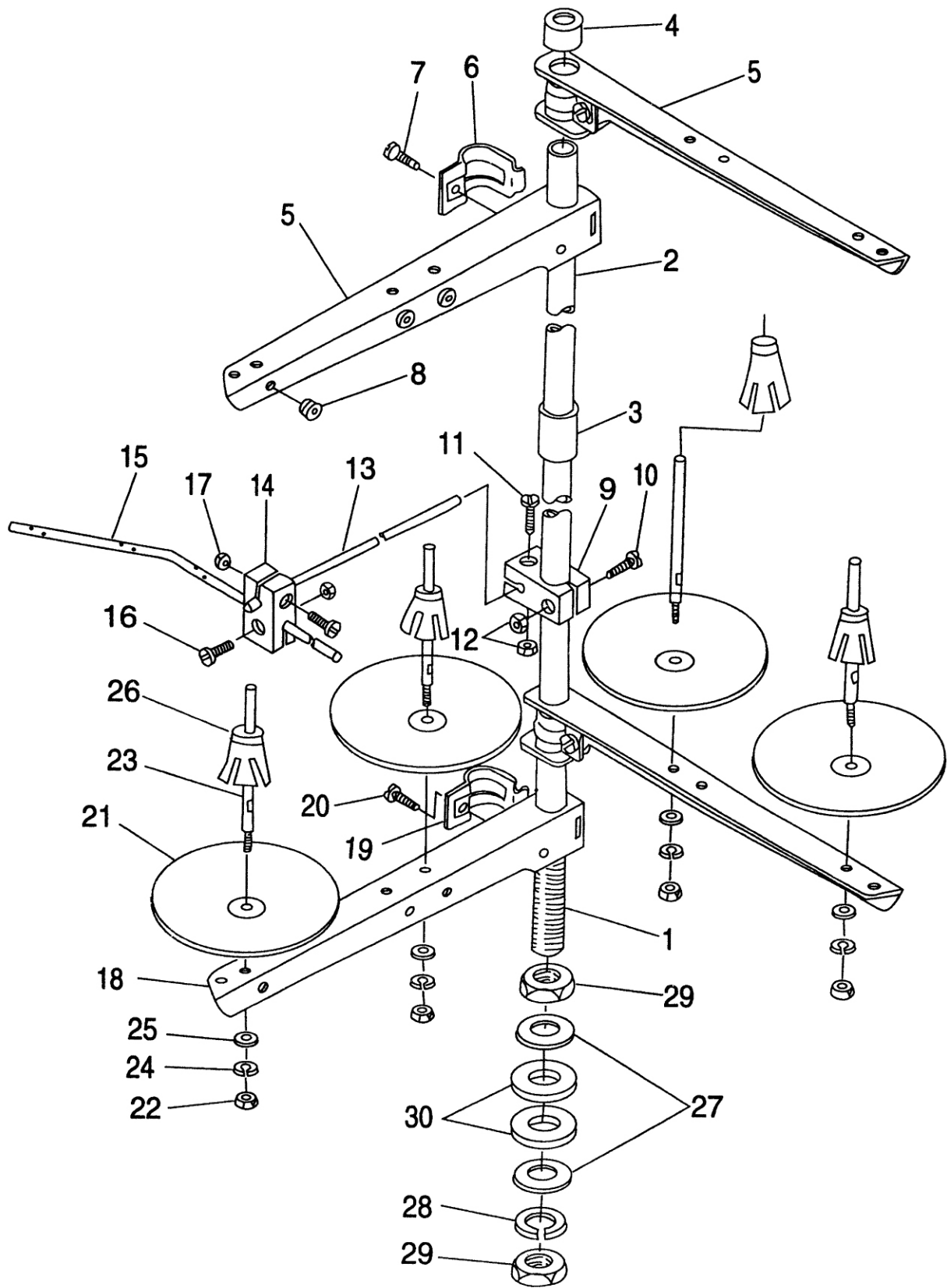

11、四线团架分组件 Quadruple-thread spool stand asm.

序号 Ref. No.	件号 Part No	名称	Description	数量 Amt. Req.
1	GZ315	线架杆下节	Spool rest rod (upper)	1
2	GZ316	线架杆上节	Spool rest rod (lower)	1
3	GR1932	线架杆接头	Spool rested joint	1
4	GR1744	线架杆顶防护橡皮	Spool rest rod rubber cap	1
5	GR1825	线架过线杆	Thread guide asm.	2*
6	GR1745	线架过线夹	Thread guide asm joint	2*
7	GS558	线架过线夹螺钉	Screw	2*
8	GR1784	导线圈	Thread guide ring	6**
9	GR1933	线架导线杆夹	Thread guide arm holder	1
10	GS149	线架导线杆夹螺钉(A)	Screw	1
11	GS113	线架导线杆夹螺钉(B)	Scerw	1
12	GL104	线架导线杆夹螺母	Nut	2
13	GZ317	线架导线杆	Thread guide arm	1
14	GR1934	线架导线杆过线夹	Thread guide arm holder	1
15	GR1935	线架导线杆过线	Lower thread guide	1
16	GS231	线架导线杆过线夹螺钉	Screw	2
17	GL110	线架导线杆过线夹螺母	Nut	2
18	GR1825	线盘架	Spool rest arm.	2*
19	GR1745	线盘架夹	Thread guide arm joint	2*
20	GS558	线盘架夹螺钉	Screw	2*
21	GR1811	线盘	Spool rest	4***
22	GL23	线盘钉螺母	Nut	4***
23	GS067	线盘钉	Spool pin	4***
24	GR1625	线盘钉弹簧垫圈	Spring washer	4***
25	GR1626	线盘钉垫圈	Washer	4***
26	GR1215	线团防松垫	Spool cushion	4
27	GR1696	线架杆紧固螺母垫圈	Washer	2
28	GR1751	紧固螺母弹簧垫圈	Spring washer	1
29	GL158	线架杆紧固螺母	Nut	2
30	GR1753	线架杆防震橡皮圈	Rubber washer	2

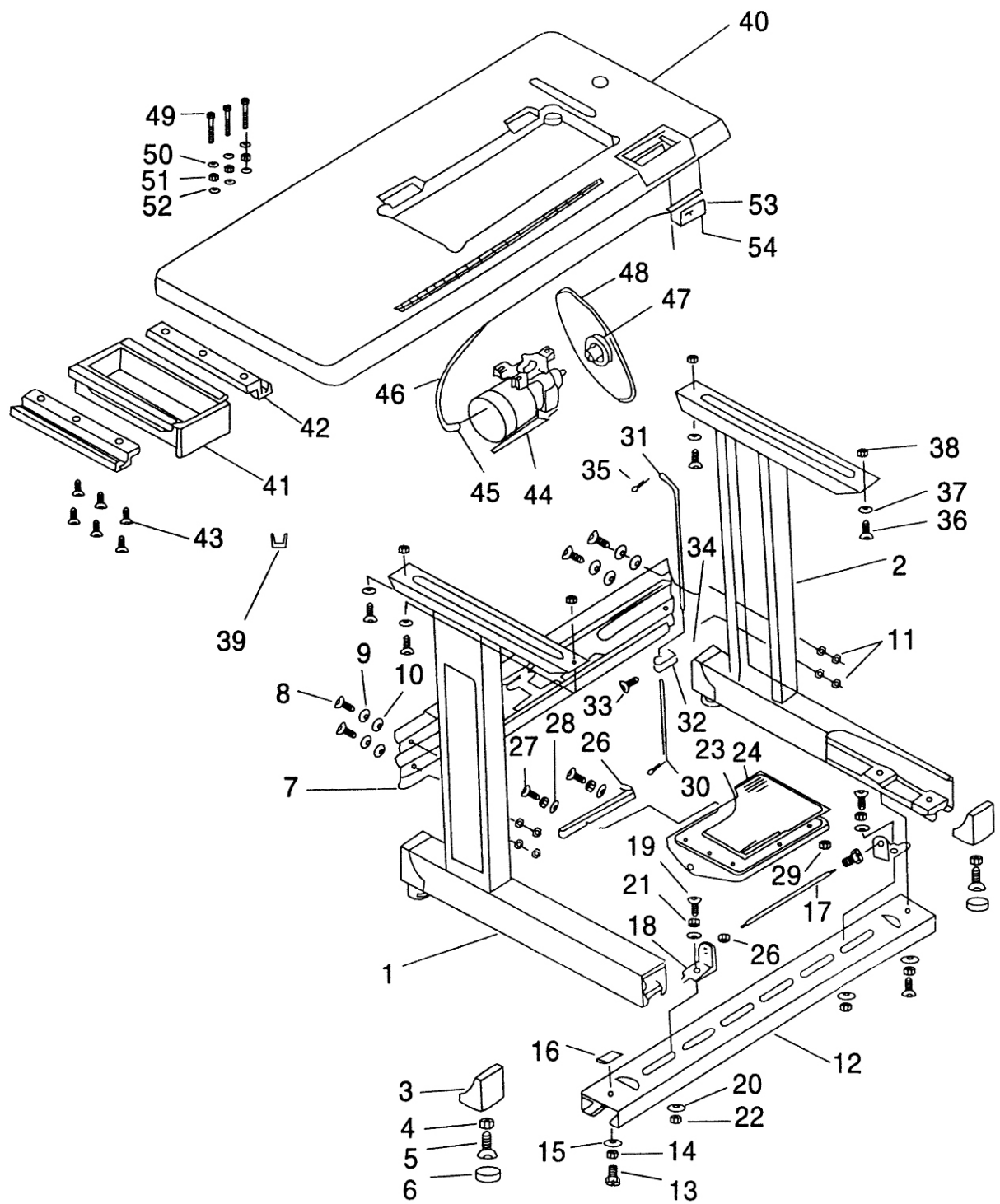

12、机架、台板、电器分组件 *

Machine stand, table & electric appliance components *

序号 Ref. No.	件号 Part No	名称	Description	数量 Amt. Req.
1	GKR302/5	边架部件(左)	Stand side asm.left	1
2	GKR305/5	边架部件(右)	Stand side asm.right	1
3	GKR318	边架座套	Rubber cushion	4
4	GKL104	调节座螺母	Nut	4
5	GKR196/2	调节座	Screw	4
6	GKR198	调节座胶垫	Space ring	4
7	GKR309	横档	Stand side support	1
8	GKS110	横档连接螺钉	Screw	4
9	GKR106	边架柱弹簧垫圈	Spring washer	4
10	GKR122	边架柱垫圈	Washer	8
11	GKL101	横档固定螺母	Nut	4
12	GKR310	踏板轴档	Treadle brace	1
13	GKS110	踏板轴档螺钉	Screw	2
14	GKR106	踏板轴档弹簧垫圈	Spring washer	2
15	GKR122	踏板板轴档垫圈	Washer	2
16	GKR311	踏板轴档定位螺母板	Treadle brace lock nut plate	2
17	GKX301	踏板轴	Treadle shaft	1
18	GKR317	踏板轴座	Treadle bracket	2
19	GKS110	踏板轴座螺钉	Screw	2
20	GKR122	踏板轴座垫圈	Washer	4
21	GKR106	踏板轴座弹簧垫圈	Spring washer	2
22	GKL101	踏板轴座螺母	Nut	2
23	GKR312	踏板	Treadle	1
24	GKR313	踏板垫	Gasket	1
25	GKR314	踏板衬套	Collar	2
26	GKR315	踏板杠杆	Treadle pitman	1
27	GKS102	踏板杠杆螺钉	Screw	2
28	GKR112	踏板杠杆垫圈	Washer	4
29	GKL102	踏板杠杆螺母	Nut	2
30	GKR116	下拉杆	Pitman rod, lower	1
31	GKR118	上拉杆	Pitman rod, upper	1
32	GKR183	拉杆接头	Joint	1
33	GKS110	拉杆接头螺钉	Joint screw	1
34	GKL101	拉杆接头螺母	Joint nut	1
35	GKX101	上拉杆开口销	Pitman rod split pin (upper)	1
36	GBS114	台板木螺钉	Table wood screw	4
37	GKR112	台板木螺钉垫圈	Table wood screw washer	4
38	GKR186	台板垫圈	Table washer	4
39	GBR156	抽斗限位	Drawer limit plate	1
40	GBR158/2	台板组件	Table	1
41	GBR203/2	抽斗部件	Drawer	1
42	GBR206	抽斗导轨	Drawer rail	2
43	GBS121	抽斗导轨木螺钉	Drawer rail wood screw	6
44	GD234	GFC4024型电机	Model GFC4024 motor	1
45	GD219	电机接线插头	Motor connecting wire plug	1
46	GD108	电机接线	Motor wire	1
47	GD023/3	电动机带轮	Motor pulley	1
48	GE122	机头传动带	Machine driving belt	1
49	GKS122	电机台板连接螺钉	Motor & table connecting screw	3
50	GKR209	电机台板连接垫圈	Motor & table connecting washer	3
51	GKR106	电机台板连接弹簧垫圈	Motor & table connecting spring washer	3
52	GKL101	电机台板连接螺母	Motor & table connecting nut	3
53	GD227	电源开关	Power source switch	1
54	GBS104	电源开关木螺钉	Power source switch wood screw	2

*本分组件需另行订购

* Note that parts abve mentioned shall be purchased in a separate order

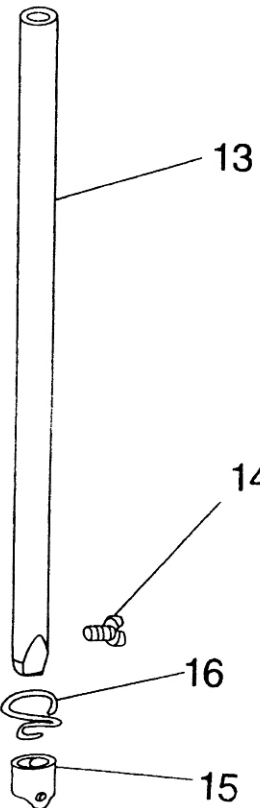
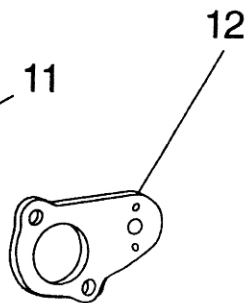
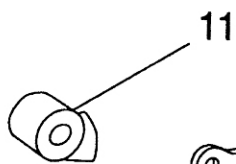
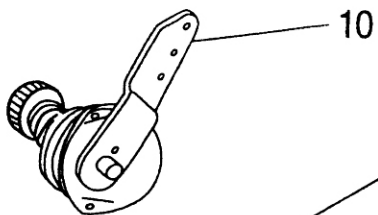
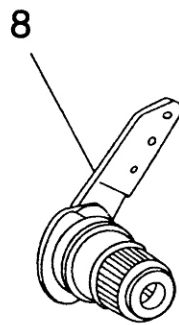
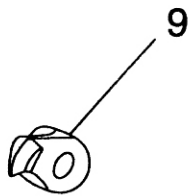
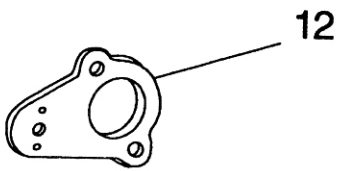
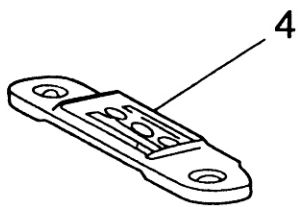
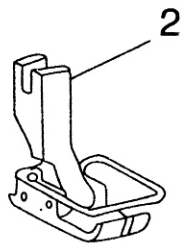
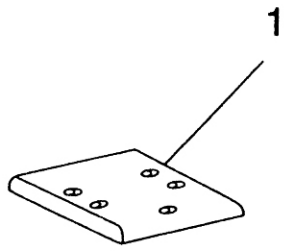







13、高速单针链缝机





Model one-needle high speed chainstitcher

序 号 Ref. No.	件 号 Part No	名 称	Description	数 量 Amt. Req.
1	GM274	附件安装板	Attachment installing plate	1
2	GM275/7	压脚部件	Presser foot asm.	1
3	GM276	送料牙	Feed dog	1
4	GM277	针 板	Throat plate	1
5	GR1998	弯针曲柄挡圈	Throat collar	1
6	GR1999	摆动护针杆	Driving needle guard	1
7	GR2000	固定护针杆	Counter needle guard	1
8	GR2001/9	面线夹线器部件	Needle thread tension asm.	1
9	GR2002	面线松线爪	Tension release latch	1
10	GR2003/11	底线夹线器部件	Lower thread tension asm.	1
11	GR2005	底线夹线爪	Looper thread release latch	1
12	GR2004	夹线器安装板	Tension installing plate	2
13	GZ318	针 杆	Needle bar	1
14	GS071	支针螺钉	Screw	1
15	GR1481	针杆线钩	Needle bar thread guide	1
16	GR1480	针杆下衬套线钩	Thread guide	1

双针链缝机（横列）附件一览表 List of accessories for double-needle chainstitcher

名称 Name		针板 Throat plate	针夹 Needle clamp	压脚 Presserfoot asm	送料牙 Feed dog	摆动护针杆 Driving needle guard	右固定护针杆 Counter needle guard right	左固定护针杆 Counter needle guard left	
规格 Specifications									
		*1 1/8"(3.2mm)	GM252	GR1937	GM253/5	GM254			
		2 5/32"(4.0mm)	GM255	GR1944	GM256/5	GM250	GR1936		
		3 3/16"(4.8mm)	GM251	GR1929	GM249/5				
		4 7/32"(5.6mm)	GM257	GR1951	GM258/5	GM247	GR1857		GR1859
		5 1/4"(6.4mm)	GM248	GR1826	GM246/5			GR1860	
		6 5/16"(7.9mm)	GM259	GR1958	GM260/5	GM261			
		7 3/8"(9.5mm)	GM263	GR1966	GM264/5	GM265	GR1960		
		8 1/2"(12.7mm)	GM266	GR1973	GM267/5	GM268	GR1975		
双针纵列链缝机 Vertical Double-needle chainstitcher									
9	0	GM272	GR1989	GM271	GM273	GR1992		GR1993	

双针链缝机 (横列) 附件一览表 List of accessories for double-needle chainstitcher

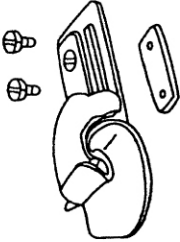
名称 Name		右弯针 Right Looper	左弯针 Left Looper	推板 Bed slide	凸轮盖 Cam Cover	卷边器 Folder							
规格 Specifications													
							*1	1/8"(3.2mm)	GN170	GN169	GM245	GM262	GR1939/5
							2	5/32"(4.0mm)	GN170	GN169	GM245	GM262	GR1946/5
							3	3/16"(4.8mm)	GN170	GN169	GM245	GM262	GR1924/5
							4	7/32"(5.6mm)	GN170	GN169	GM245	GM262	GR1953/5
							5	1/4"(6.4mm)	GN170	GN169	GM245	GM262	GR1916/5
							6	5/16"(7.9mm)	GN170	GN169	GM245	GM262	GR1961/5
							7	3/8"(9.5mm)	GN170	GN169	GM245	GM262	GR1968/5
							8	1/2"(12.7mm)	GN170	GN169	GM269	GM270	
双针纵列链缝机 Vertical Double-needle chainstitcher													
9	0	GN170	GN169	GM245	GM243								

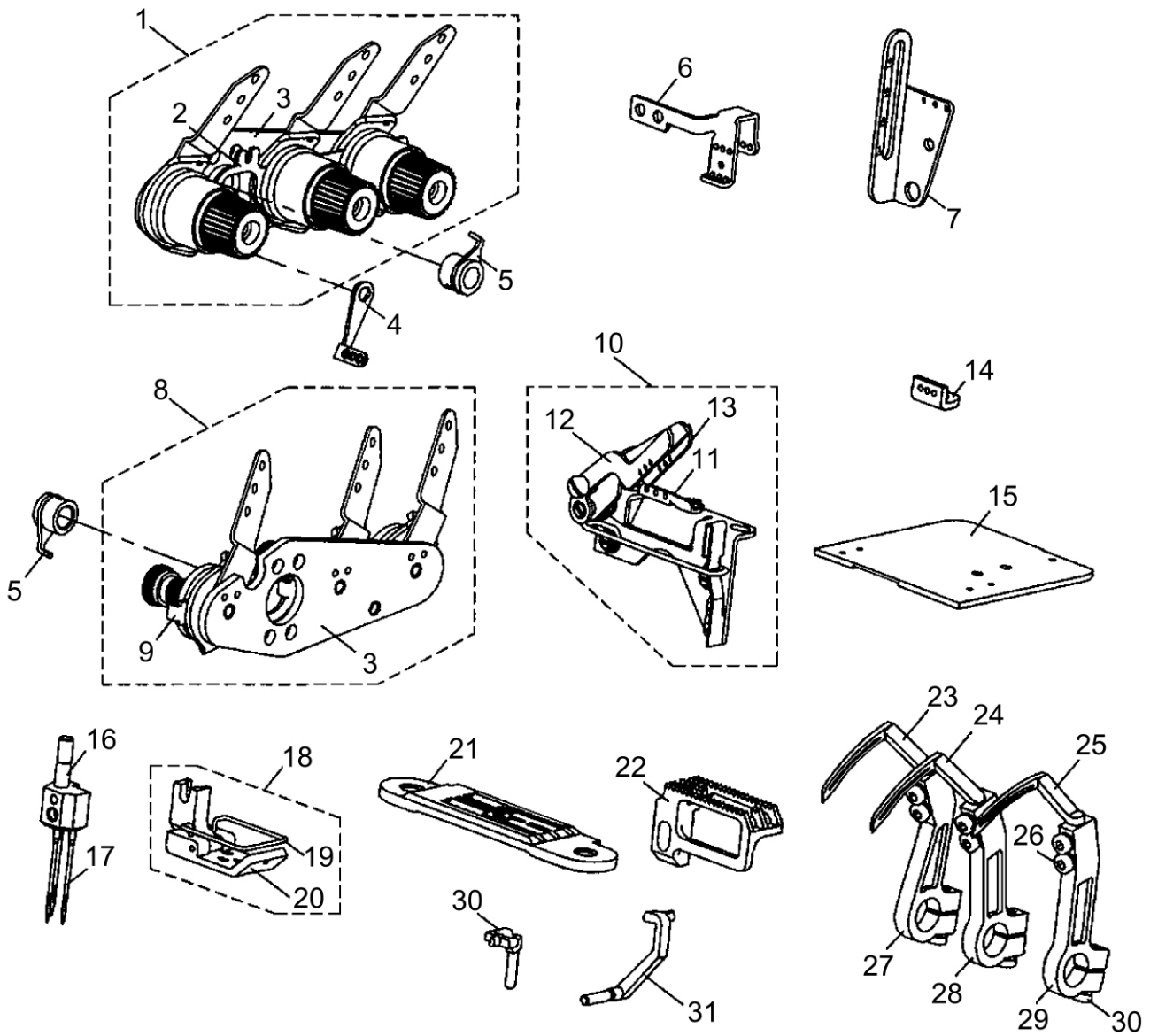

14、高速三针链缝机

Three needle high speed chainstitch

序号 Ref. No.	件号 Part No	名称	Description	数量 Amt. Req.
1		面线夹线器部件	Looper thread asm.	1
2	GR2113	面线松线推板	Release slide plate	1
3	GR2112	三针夹线器安装板	Looper thread releage latch	2
4	GR2120	三针导线勾	Frame thread guide	1
5	GR2109	三针松线勾组件	Tension relead latch	1
6	GR2103	挑线杆	Thread take-up.	1
7	GR2104	中间导线勾	Frame thread eyelet	1
8		底线夹线器部件	Lower thread tension asm.	1
9	GR2114	底线松线推板	Lower thread release slide plate	1
10		三针打线凸轮组件	Looper thread guide asm.	1
11	GR2105	底线三线导线勾	Cast-off plate	1
12	GR2106	左凸轮导线勾	Looper thread guide left	1
13	GR2107	右凸轮导线勾	Looper thread guide right	1
14	GR2108	底线导线勾	Thread guide	1
15	GM282	三线凸轮盖	Cam cover	1
16	GR2102	针夹	Needle clamp	1
17		机针 (14#~18#)	Needle	3
18		三针压脚组件	Presser foot asm.	1
19	GR2101	保针架	Finger guard	1
20	GR2100	压脚板	Presser foot	1
21	GM280	针板	Throat plante	1
22	GR281	送料牙	Feed dog	1
23	GN170	右弯针	Right looper	1
24	GN171	中弯针	Middle looper	1
25	GN169	左弯针	Left looper	1
26	GS788	三针弯针螺钉	Screw	6
27	GR2119	右弯针曲柄	Looper holder asm.(right)	1
28	GR2117	中弯针曲柄	Looper holder asm.(middle)	1
29	GR2117	左弯针曲柄	Looper holder asm.(left)	1
30	GS0140	三针弯针曲柄螺钉	Screw	3
31	GR2116	摆动护针	Driving needle guard	1
32	GR8744	左固定护针	Counter needle guard	1

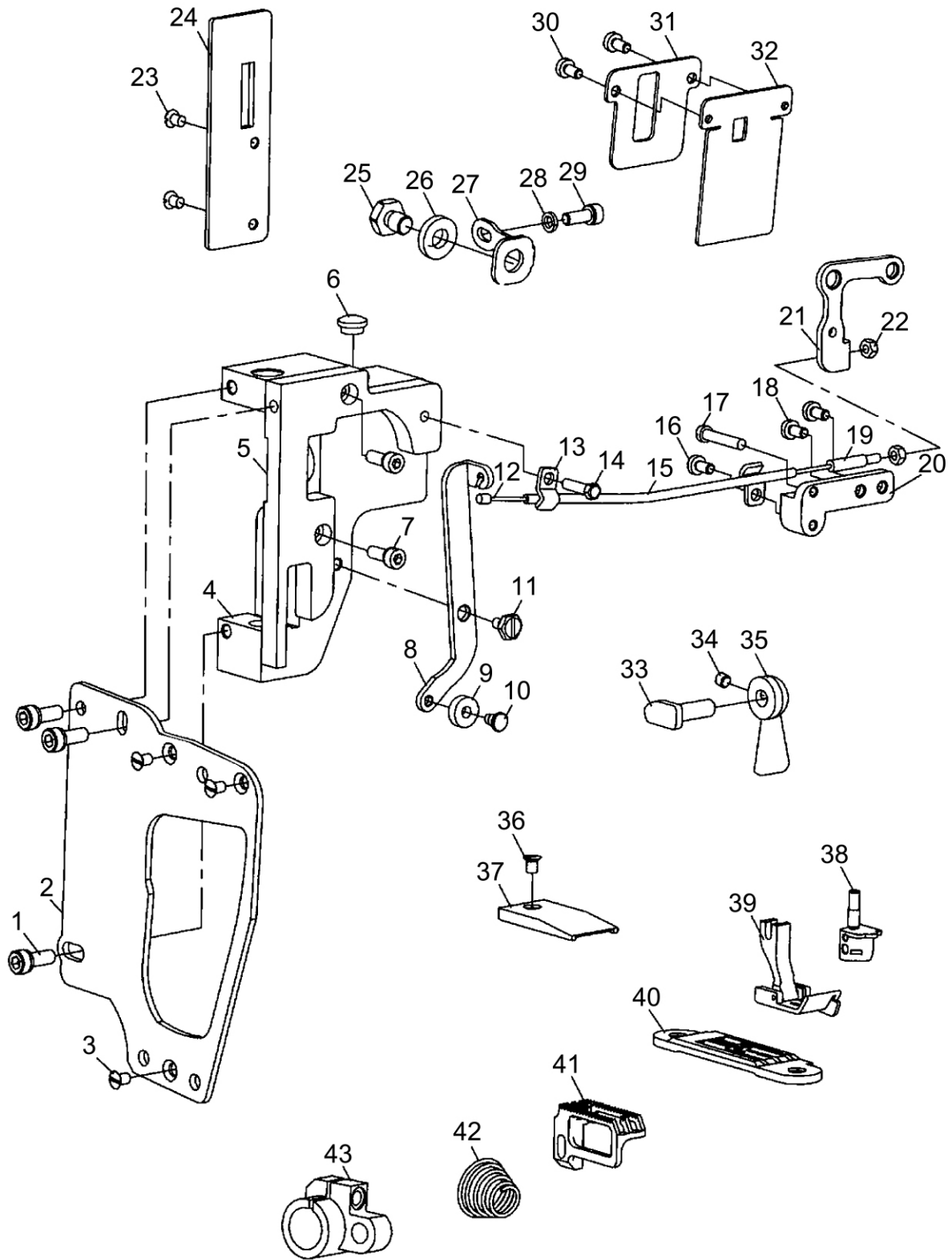

15、高速三针厚料链缝机(带拖布轮)分组件(1)

Three needle high speed heavy duty (with puller) component

序号 Ref. No.	件号 Part No	名称	Description	数量 Amt. Req.
1	GS2080	拖轮箱螺钉	Screw	3
2	GR8711	拖轮箱面板	Puller plate	1
3	GS044	拖轮箱面板螺钉	Screw	3
4	GR8709	拖轮箱	Puller box	1
5	GR8715	拖轮箱支座	Puller box support	1
6	GR1462	拖轮箱孔塞	Rubber cap	1
7	GS2082	拖轮箱支座螺钉	Screw	2
8	GR8717	提升杠杆	Lever	1
9	GR8714	提升滚动轴承	Ball bearing redial	1
10	GR8719	提升滚柱螺钉	Screw	1
11	GR8718	提升杠杆螺轴	Shoulder screw	1
12	GR8733	提升钢丝绳	Wire	1
13	GR8736	拉索夹	Wire holder	2
14	GS2085	前拉索夹螺钉	Screw	1
15	GR8735	提升钢丝软管	Soft tube	1
16	GS01	拉索夹螺钉	Screw	2
17	GS0142	弹簧长螺钉	Screw	1
18	GS81	线夹支座螺钉	Screw	2
19	GR8734	提升钢丝调节螺钉	Screw	1
20	GR8725	线夹支座	Thread tension support	1
21	GR8737	抬压脚后杠杆	Lifting lever link rear	1
22	GL311	拉索螺母	Nut	2
23	GS044	拖轮箱方盖螺钉	Screw	2
24	GR8710	拖轮箱方盖	Puller cover	1
25	GS2084	拖轮箱支板螺栓	Bolt	1
26	GR8738	拖轮箱支板螺栓垫圈	Washer	1
27	GR8731	拖轮箱支板	Puller support plate	1
28	GR3371	支板螺钉弹簧垫圈	Washer spring	1
29	GS2082	拖轮箱支板螺钉	Screw	1
30	GS81	挡油罩螺钉	Screw	2
31	GR8706	挡油罩	Oil-protection cover	1
32	GR8745	挡油罩垫	Oil-protection gaskets	1
33	GR8744	扳手凸轮组件	Lifter shaft asm.	1
34	GS038	拖轮扳手螺钉	Screw	1
35	GR8746	拖轮扳手	Lifter	1
36	GS044	拖布轮垫板螺钉	Screw	1
37	GR8730	拖轮垫板	Puller base plate	1
38	GM1107	针夹	Needle clamp	1
39	GR8743	压脚组件	Presser foot asm.	1
40	GM1106	针板	Throat plate	1
41	GM281	送料牙	Feed dog	1
42	GW1041	面线夹线簧	Tension spring	3
43	GH337	抬牙后曲柄	Feed driving shaft crank rear	1

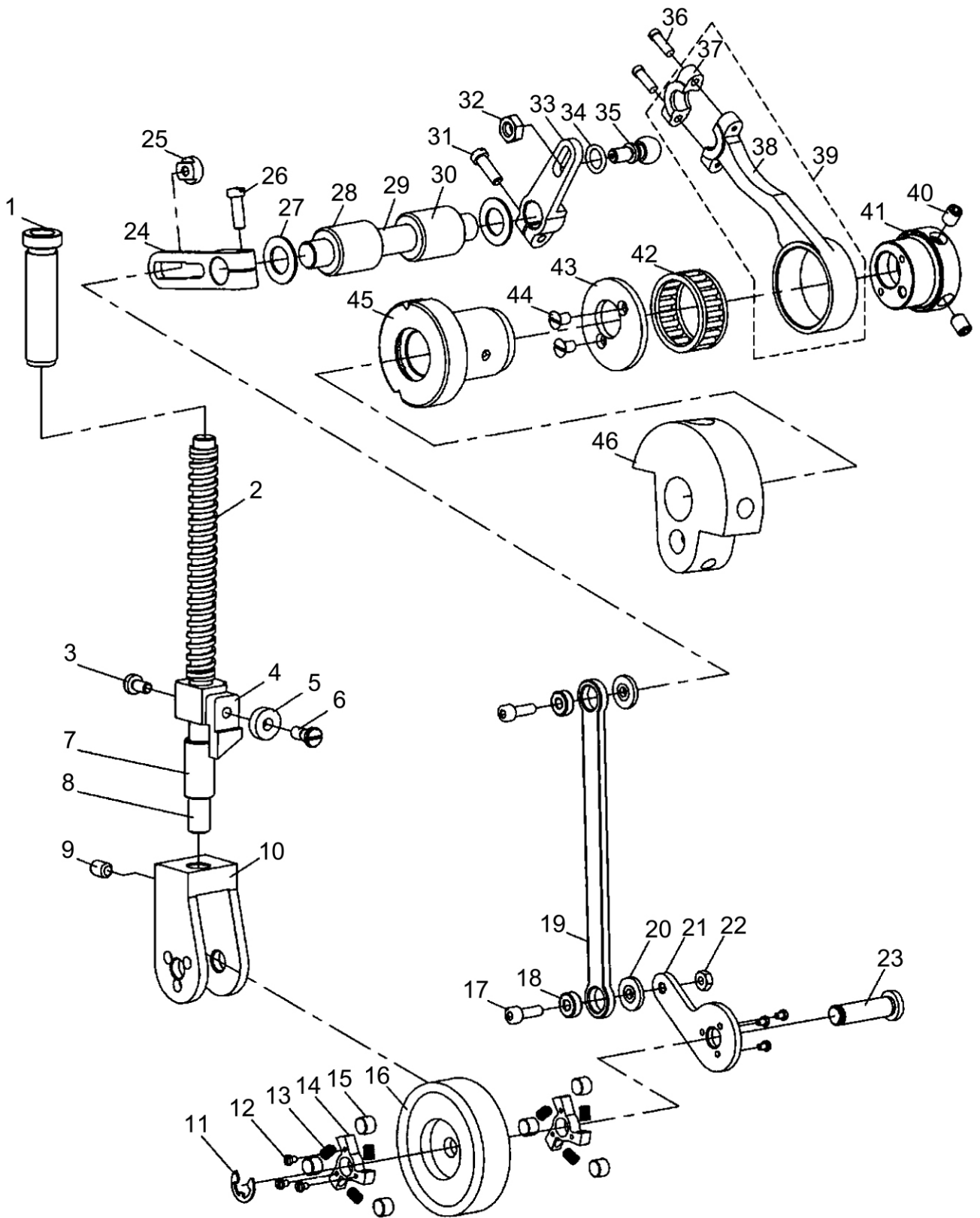

16、高速三针厚料链缝机(带拖布轮)分组件(2)

Three needle high speed heavy duty (with puller) component(2)

序号 Ref. No.	件号 Part No	名称	Description	数量 Amt. Req.
1	GR8712	拖轮调压螺母	Presser spring regulateor	1
2	GW1050	拖轮压簧	Presser spring	1
3	GS551-7	拖轮压杆滑块螺钉	Screw	1
4	GR8713	拖轮压杆滑块	Presser bar guide bracket	1
5	GR8714	滑块滚动轴承	Ball bearing radial	1
6	GS2081	滑块滚柱螺钉	Screw	1
7	GO1102	拖轮箱轴套	Shaft tube(lower)	1
8	GZ951	拖轮压杆	Presser bar	1
9	GS756	拖轮架螺钉	Screw	1
10	GR8716	拖轮架	Puller bracket	1
11	GR8724	拖轮轴卡簧	Open ring	1
12	GS970	锁紧片螺钉	Screw	6
13	GW650	转动锁紧片弹簧	Sring	6
14	GR4382	转动锁紧片	Wheel	2
15	GR4383	转动锁紧滚柱	Rolling axis	6
16	GR8726	拖布轮组件	Puller asm.	1
17	GS2083	长连杆螺钉	Screw	2
18	GR8721	长连杆轴承	Ball bearing radial	2
19	GH1082	长连杆	Connecting rod	1
20	GR8722	长连杆垫圈	Washer	2
21	GR8720	传动板	Wheel connecting rod	1
22	GL753	长连杆杆螺钉螺母	Nut	1
23	GR8723	拖轮轴	Puller shaft	1
24	GH1081	摆动曲柄	Adjusting rod(left)	1
25	GL752	摆动曲柄螺母	Nut	1
26	GS713	摆动曲柄螺钉	Screw	1
27	GR8708	摆动曲柄轴套垫圈	Washer	2
28	GO1101	摆动曲柄前轴套	Shaft tube(left)	1
29	GZ950	摆动曲柄轴	Shaft	1
30	GO1101	摆动曲柄后轴套	Shaft tube(right)	1
31	GS019	驱动摆动曲柄螺钉	Screw	1
32	GL750	球连接螺母	Nut	1
33	GH1080	驱动摆动曲柄	Ad justing rod(right)	1
34	GR8707	球连接垫圈	Washer	1
35	GR8705	驱动连杆球连接	Ball scwer	1
36	GS0140	驱动连杆螺钉	Screw	2
37		驱动连杆盖	Connecting rod cover	1
38		驱动连杆	Connecting rod	1
39	GR8704	驱动连杆组件	Connecting rod asm.	1
40	GS756	驱动偏心轮螺钉	Screw	2
41	GT810	驱动偏心轮	Eccentric wheel	1
42	GR8702	滚动轴承	Needle driving lever bearing	1
43	GR8703	驱动偏心轮盖板	Eccentric wheel thrust washer	1
44	GS0115	驱动偏心轮盖板螺钉	Screw	2
45	GO1100	上轴前轴套部件	Main shaft bushing front	1
46	GR2130	针杆曲柄	Counter weingt asm.	1



L381/L382/L383

高林股份有限公司 KAULIN MFG. CO., LTD.